

# **REINHOLD ENVIRONMENTAL Ltd.**



## **2010 APC Round Table & Expo Presentation**

July 18-20, 2010, in Concord, NC / Hosted by Duke Energy

All presentations posted on this website are copyrighted by Reinhold Environmental, Ltd (RE). Any unauthorized downloading, attempts to modify or to incorporate into other presentations, link to other websites, or obtain copies for any other uses than the training of attendees to RE's Conferences is expressly prohibited, unless approved in writing by RE or the original presenter. RE does not assume any liability for the accuracy or contents of any materials contained in this library which were presented and/or created by persons who were not employees of RE.

# ELECTROSTATIC PRECIPITATOR FUNDAMENTALS

PCUG Roundtable



Gerry Klemm-  
Southern Company

July 19, 2010

Copyright 2010 Southern Company  
All Rights Reserved

# ESP Mechanical Components

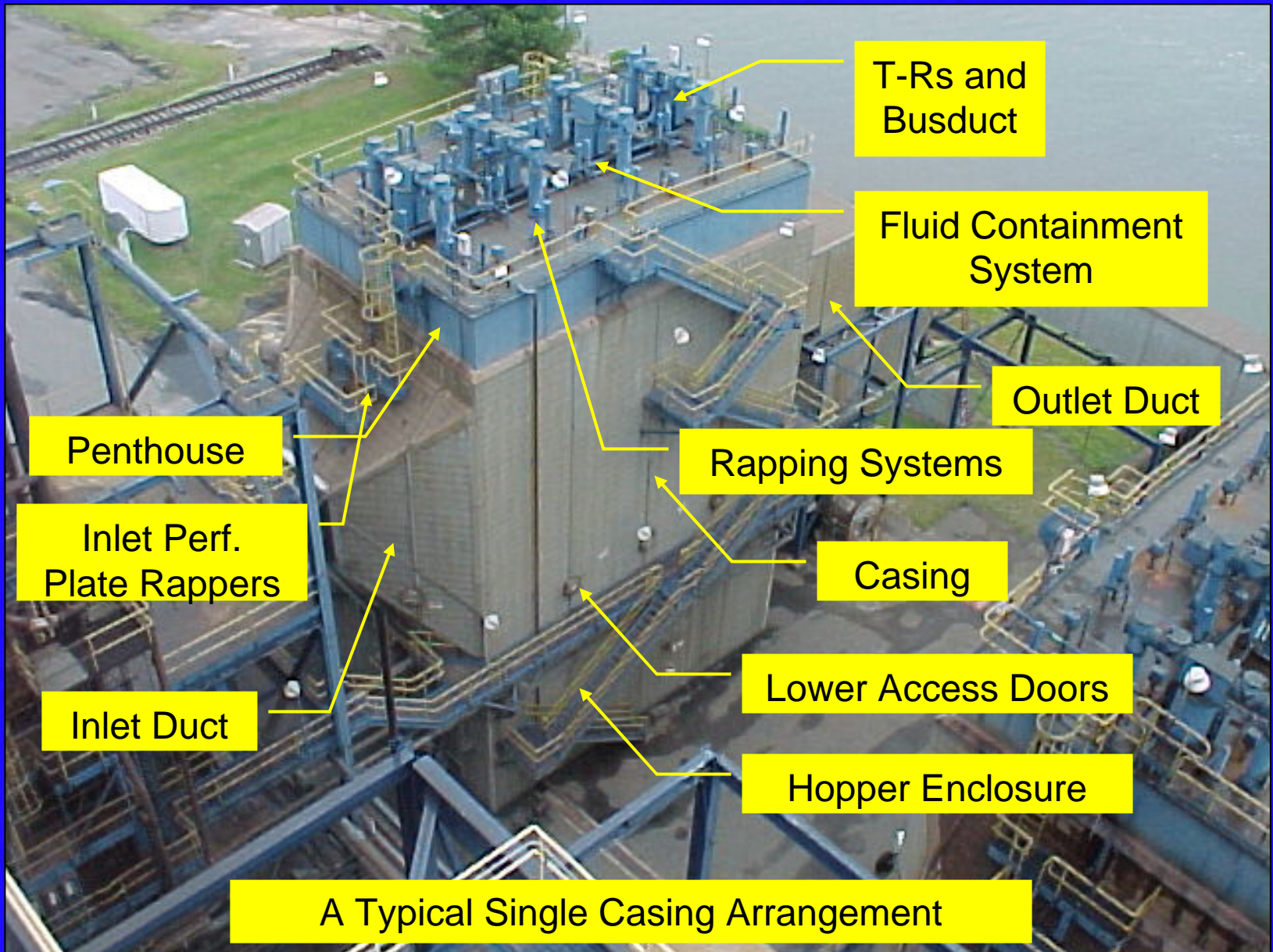

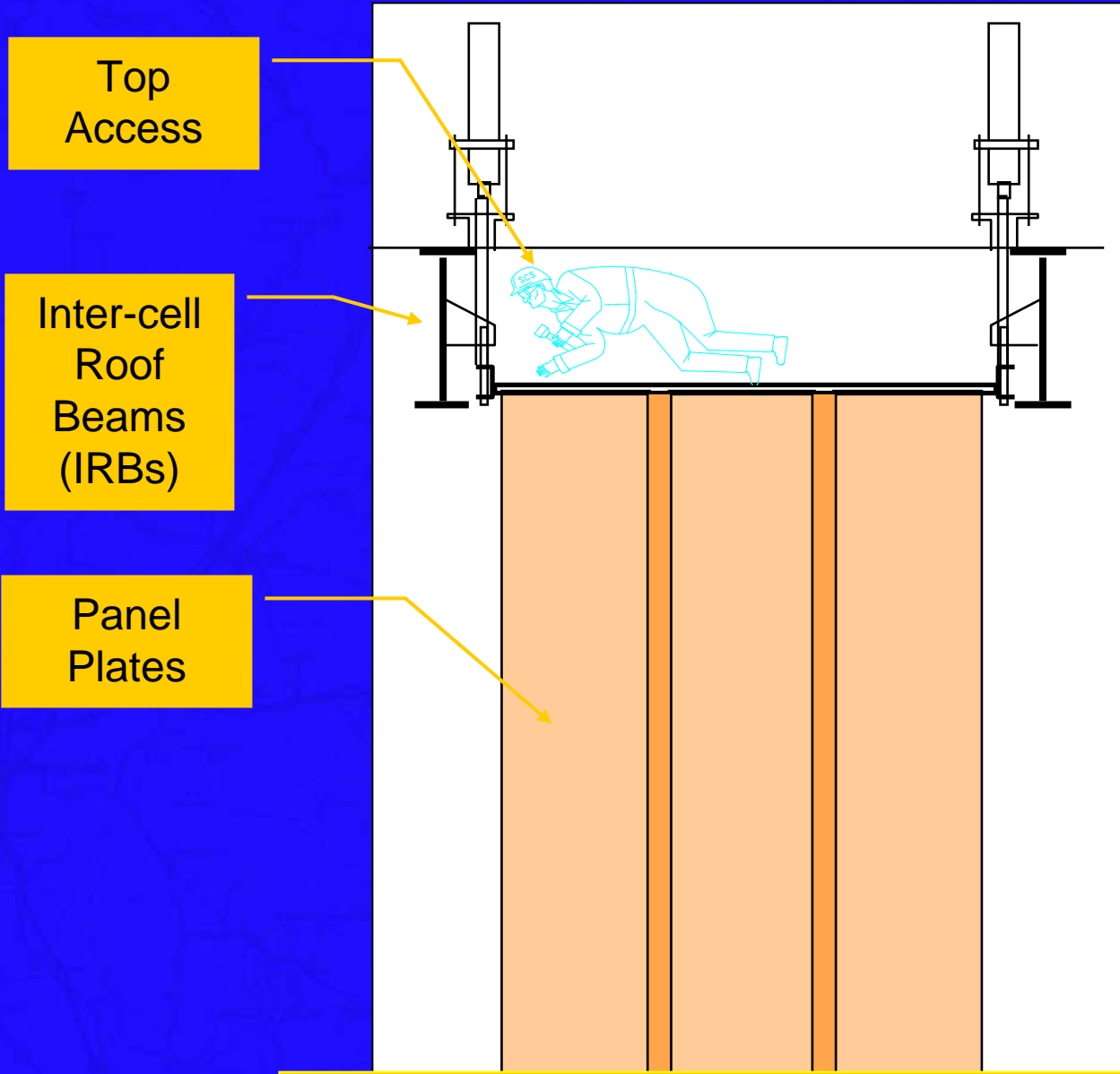

Top  
Access

Inter-cell  
Roof  
Beams  
(IRBs)

Panel  
Plates

A Typical American-Style Arrangement

Box Beams

Strip Plates

Side Access

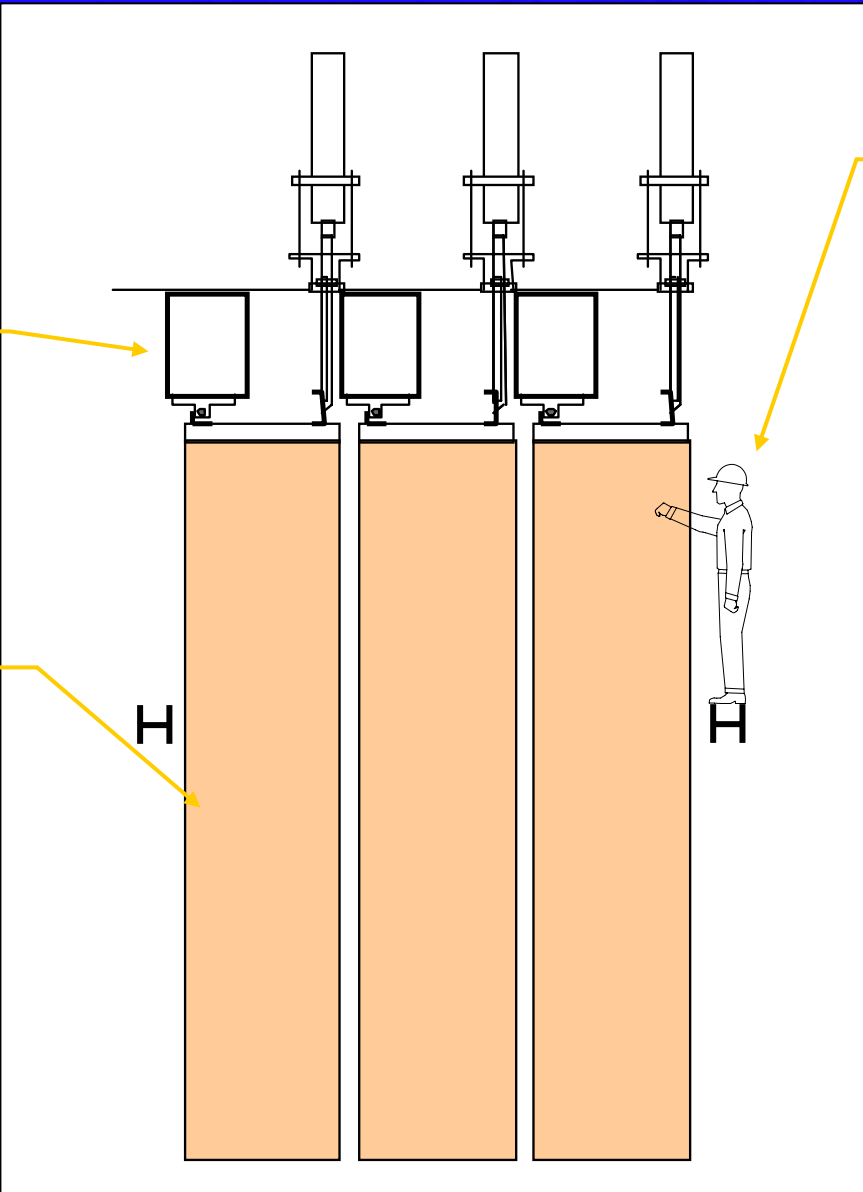

A Typical European-Style Arrangement

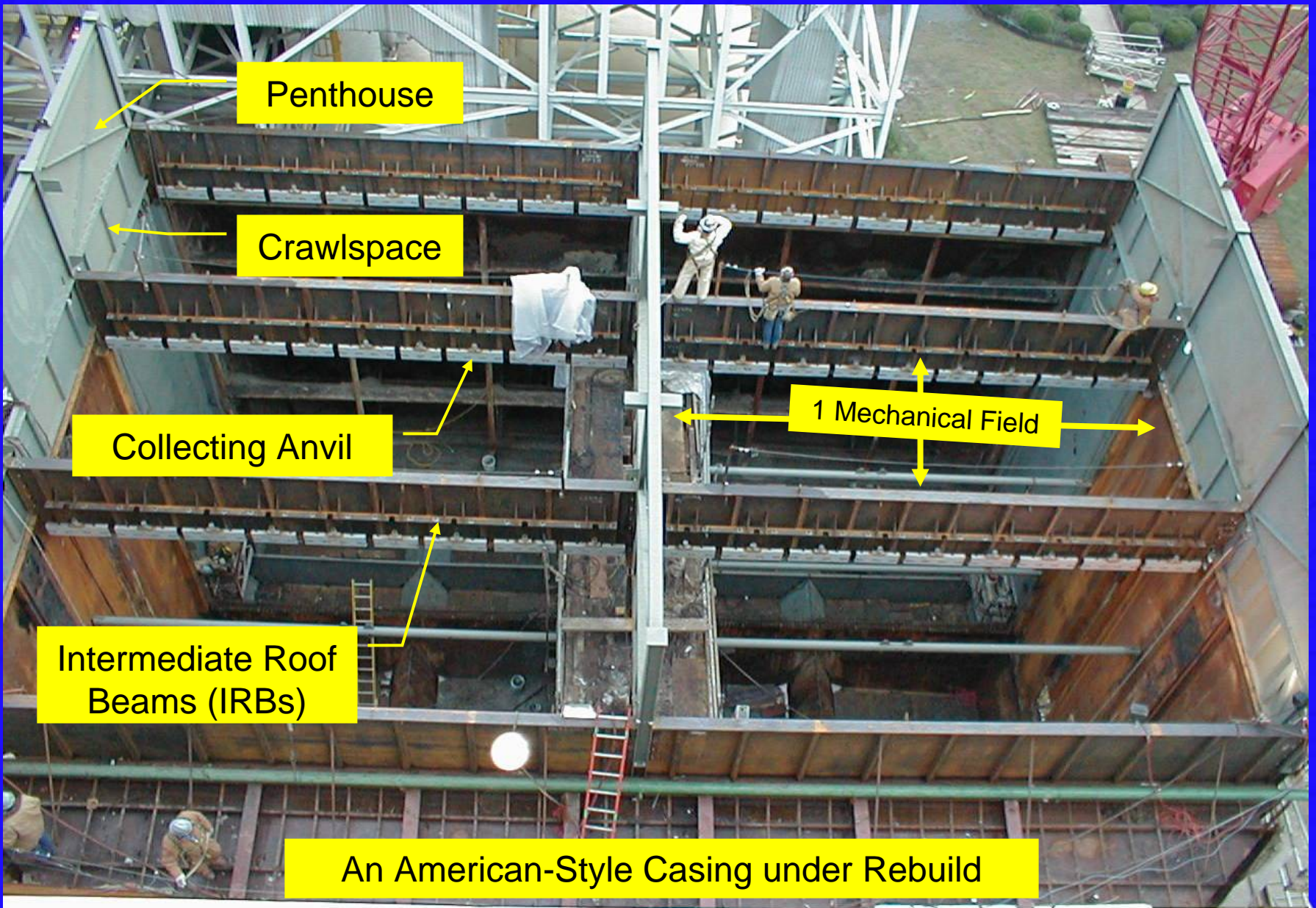

An American-Style Casing under Rebuild

Panel Style  
Plates

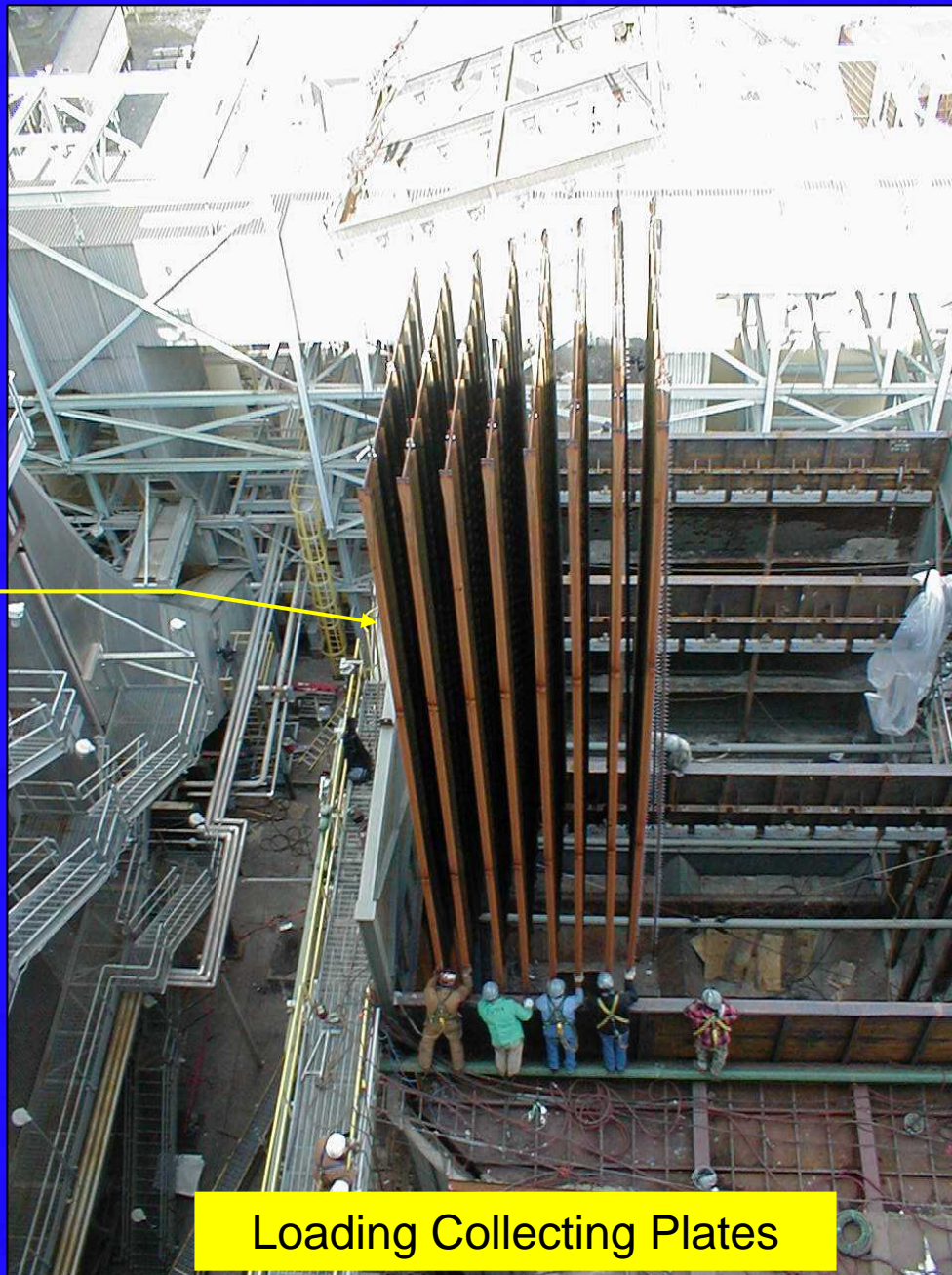

Loading Collecting Plates

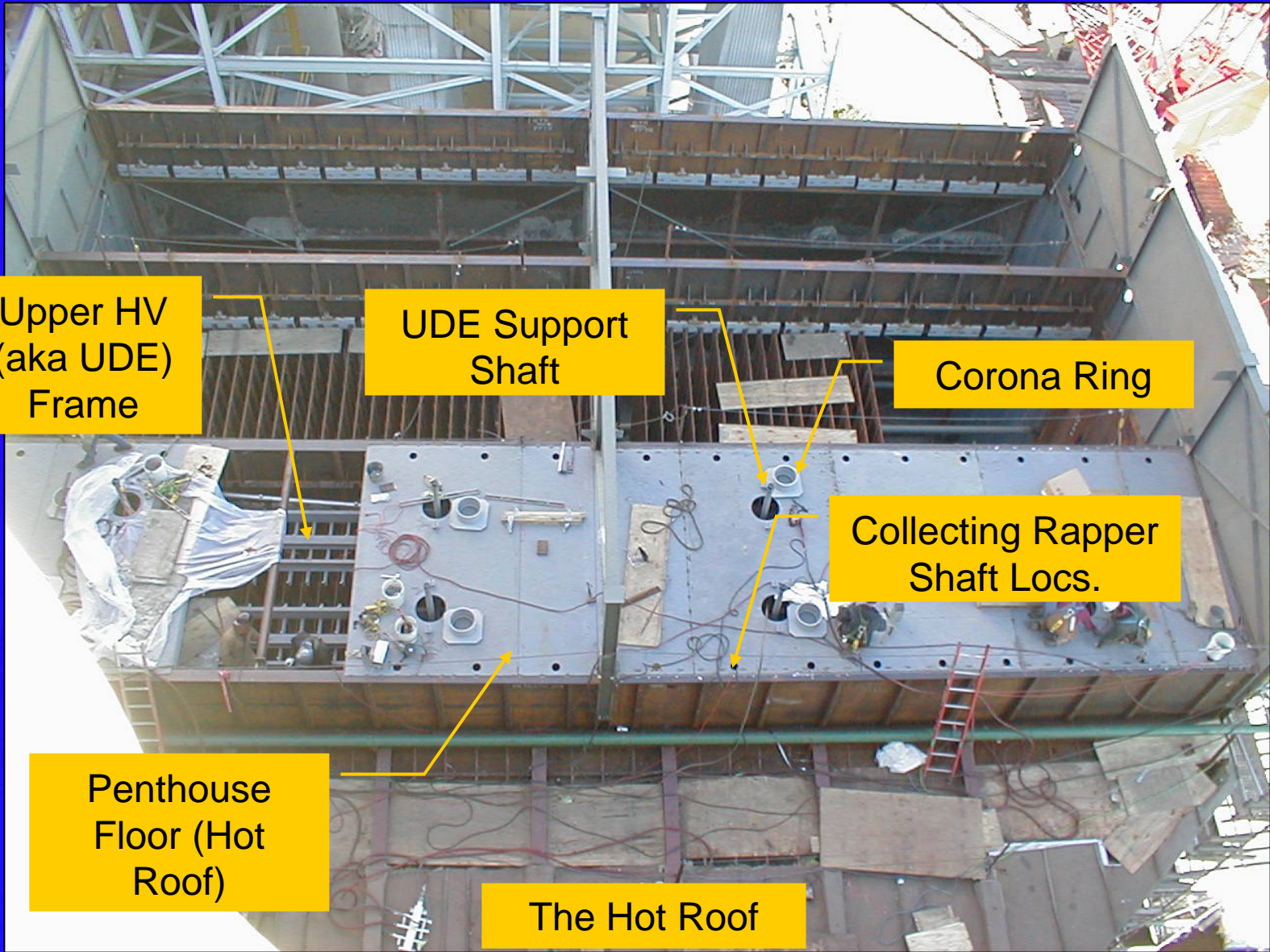

Upper HV  
(aka UDE)  
Frame

UDE Support  
Shaft

Corona Ring

Collecting Rapper  
Shaft Locs.

Penthouse  
Floor (Hot  
Roof)

The Hot Roof

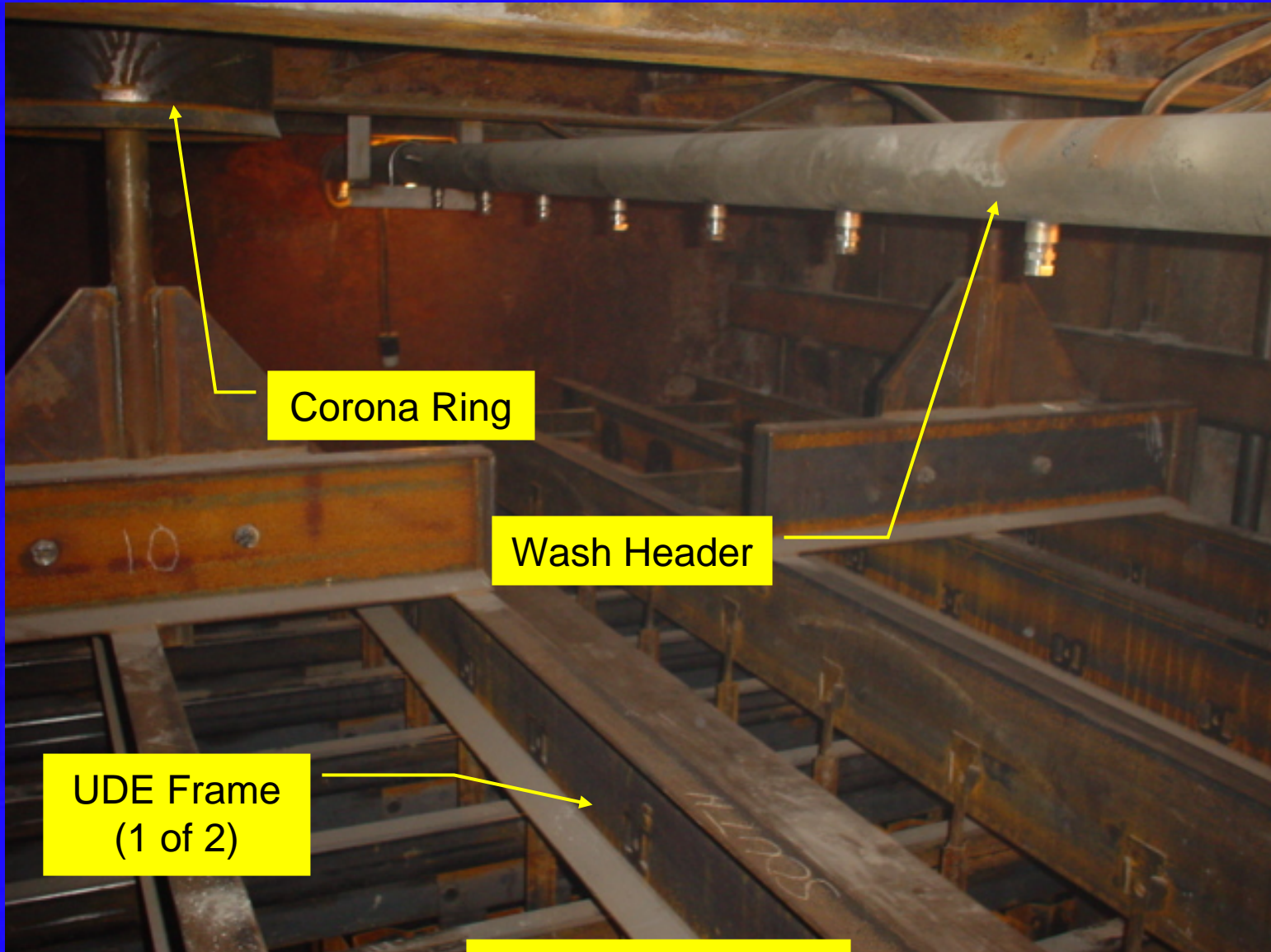

Corona Ring

Wash Header

UDE Frame  
(1 of 2)

The "Crawlspace"

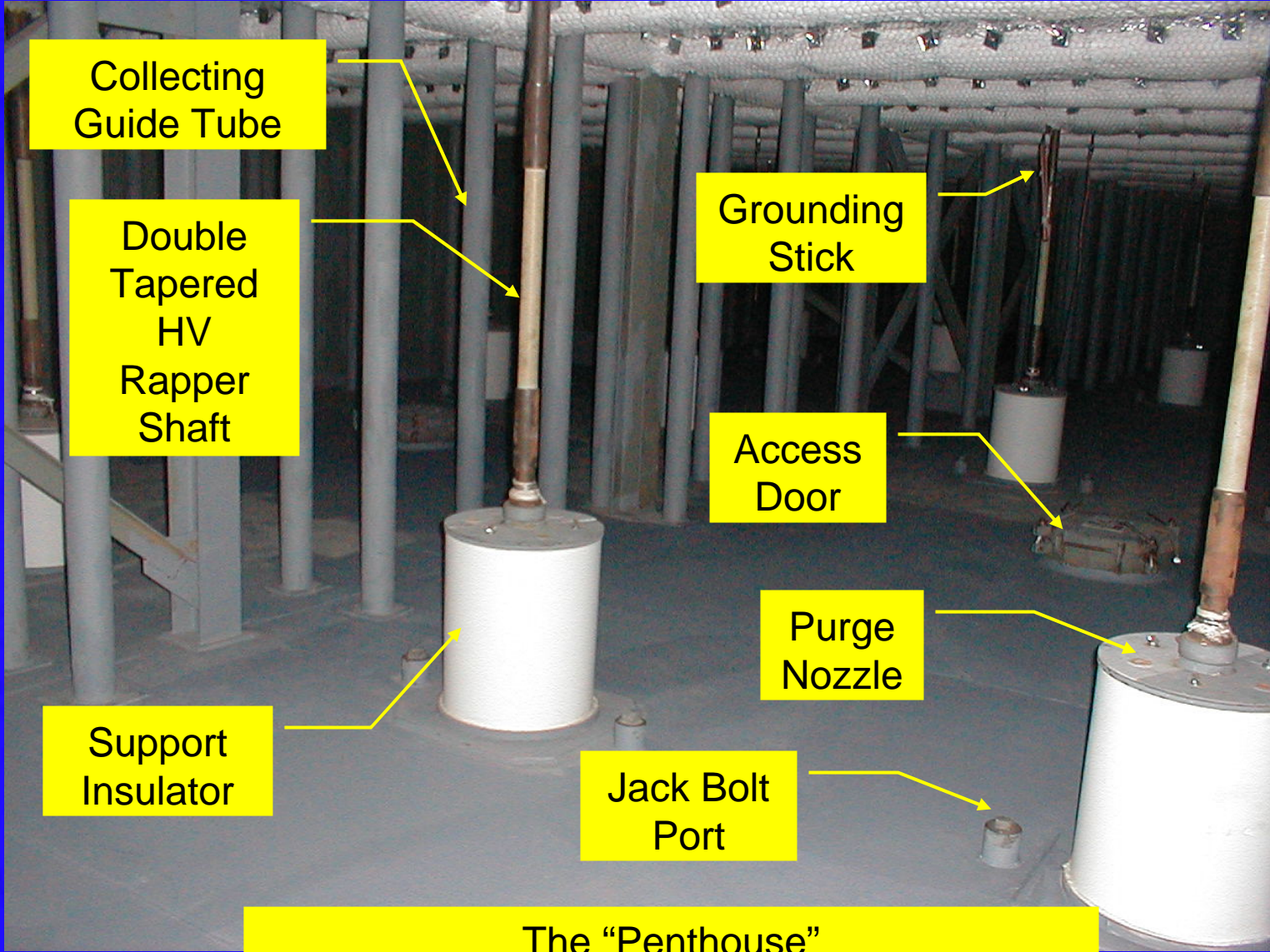

Collecting Guide Tube

Double Tapered HV Rapper Shaft

Grounding Stick

Access Door

Purge Nozzle

Support Insulator

Jack Bolt Port

The "Penthouse"

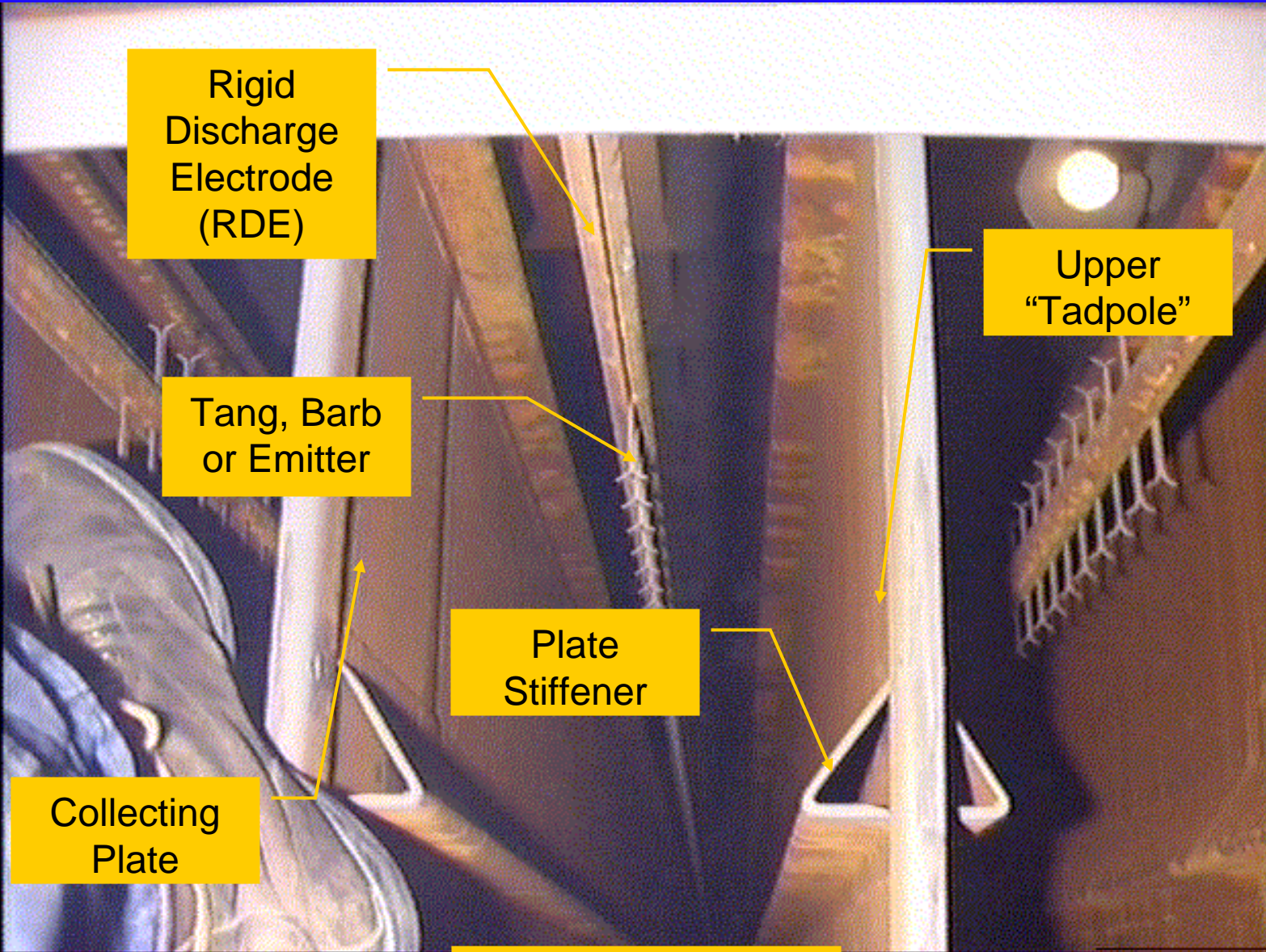

Rigid  
Discharge  
Electrode  
(RDE)

Tang, Barb  
or Emitter

Plate  
Stiffener

Upper  
"Tadpole"

Collecting  
Plate

The Gas Passage

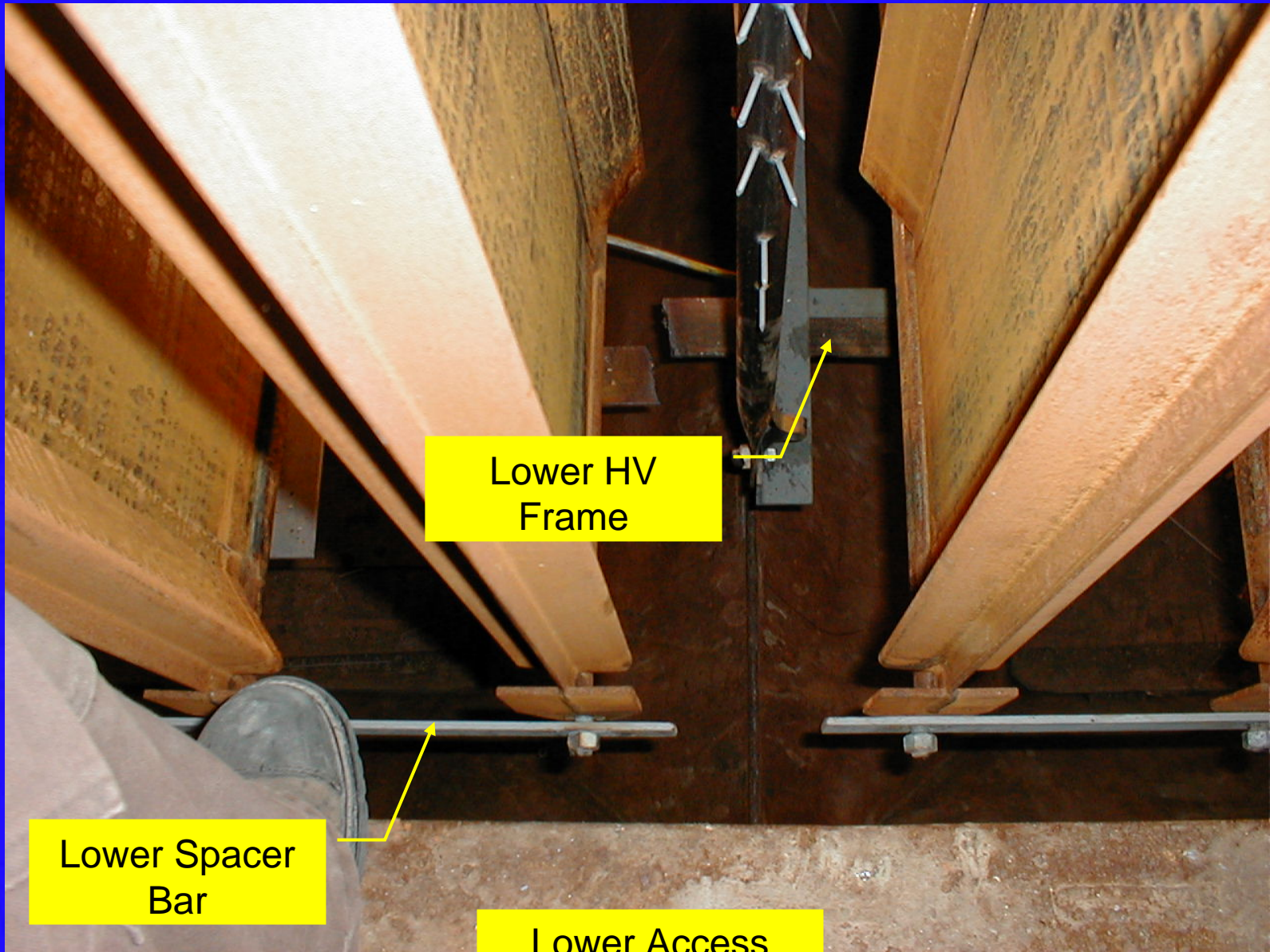

Lower HV  
Frame

Lower Spacer  
Bar

Lower Access

# Rigid Electrodes

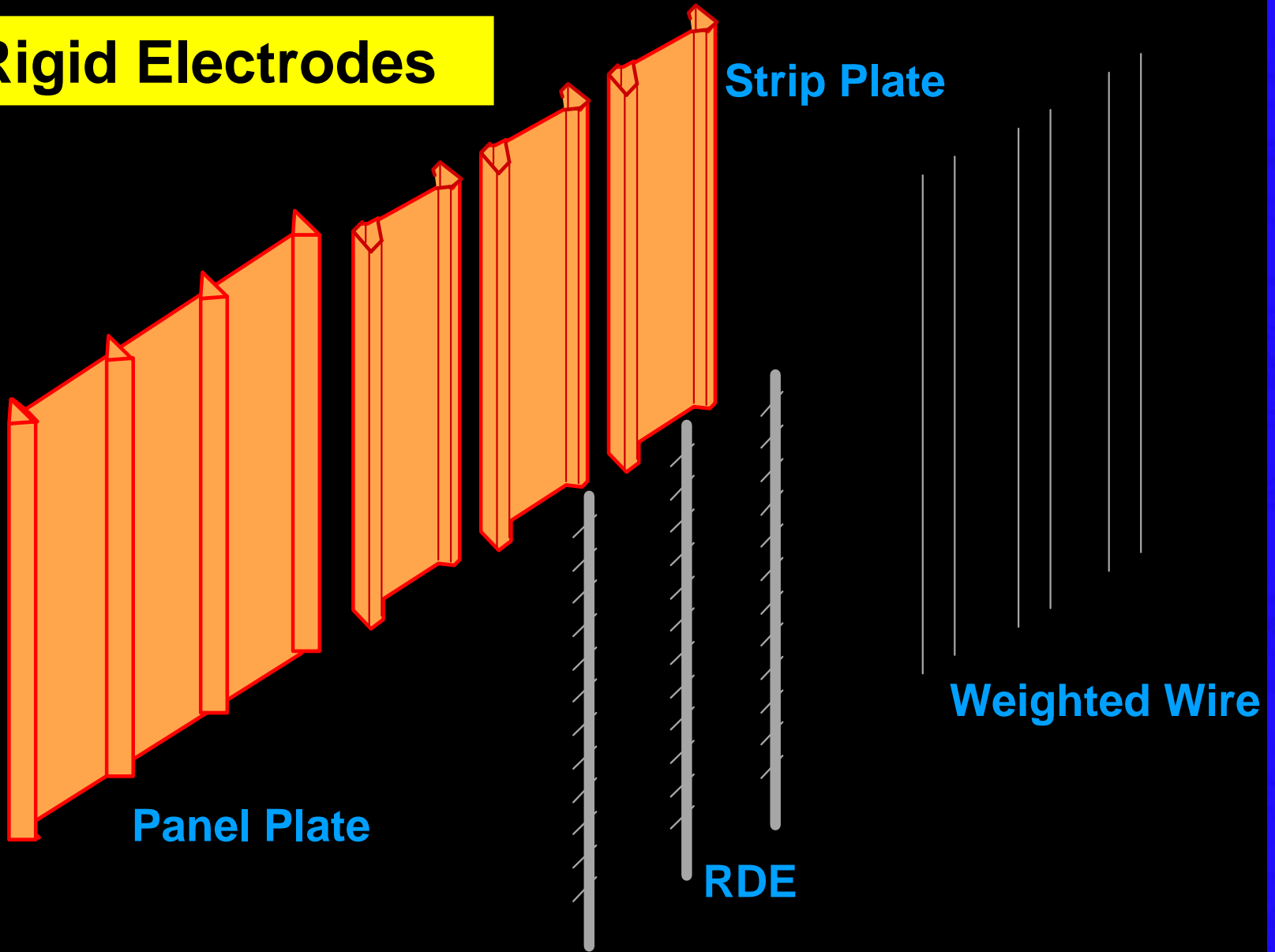

**Rigid  
Frame  
With  
Spiral  
Wires**

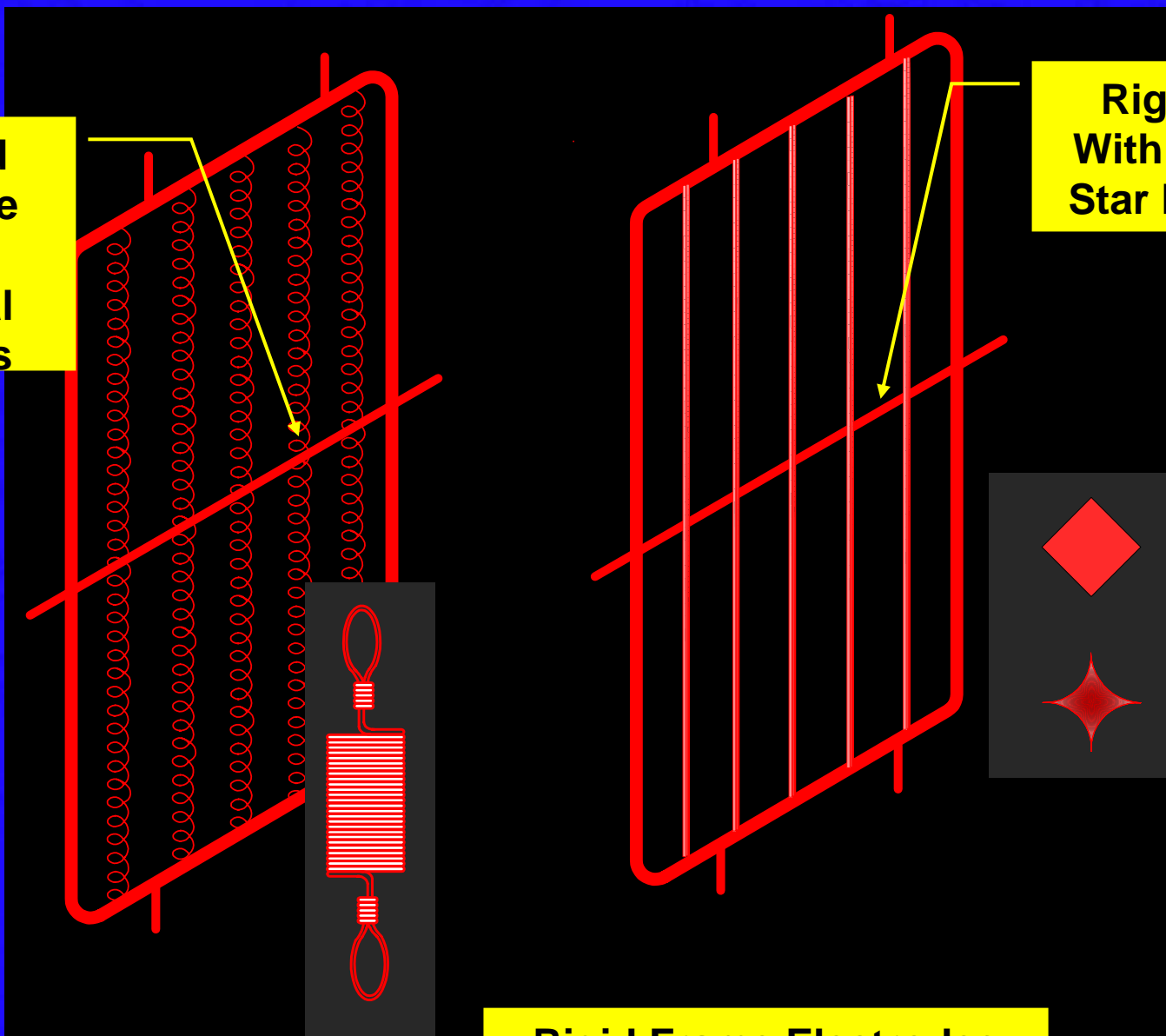

**Rigid Frame  
With Square or  
Star Electrodes**

**Rigid Frame Electrodes**

# Corona Distribution Illustration for RDEs vs. Weighted Wires

Even Distribution of Corona

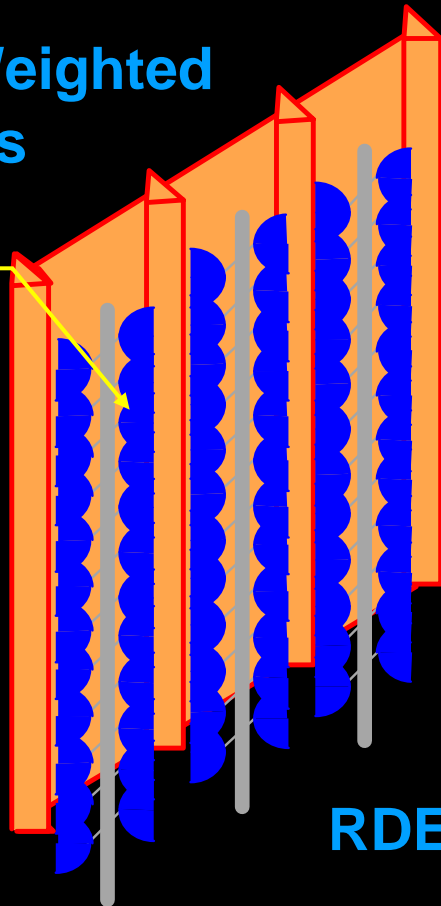

RDE

Uneven Distribution of Corona

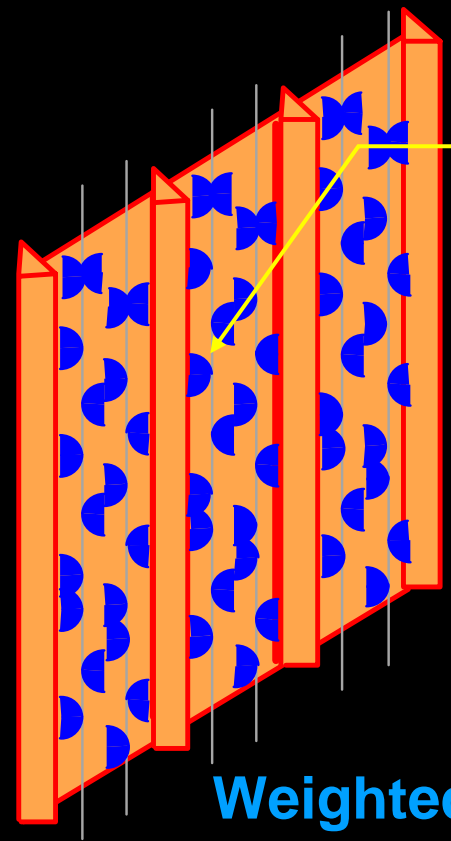

Weighted Wire

Why Different Types?

# Corona Discharge

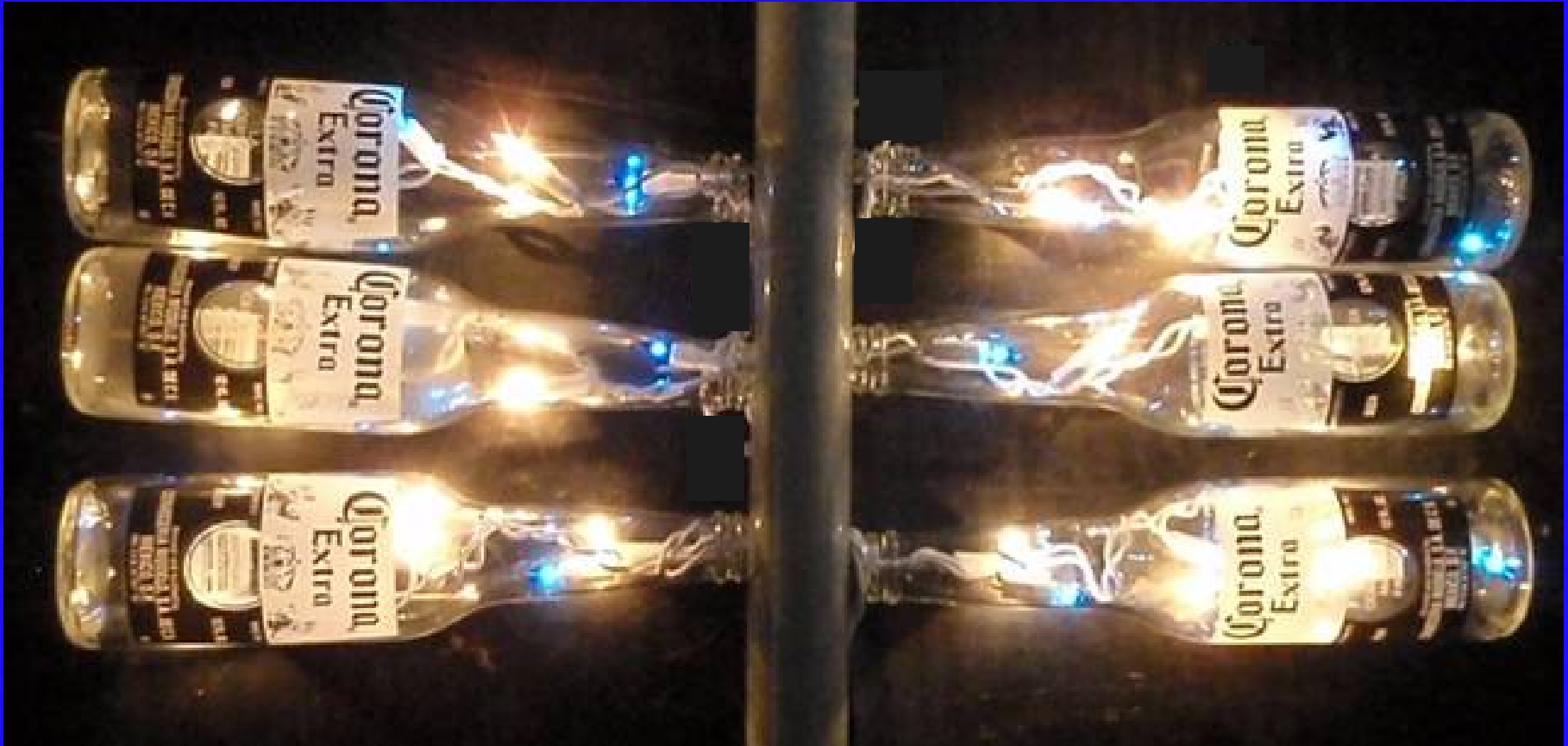

What does it look like?

# ESP Electrical Components

# Electrical Block Diagram

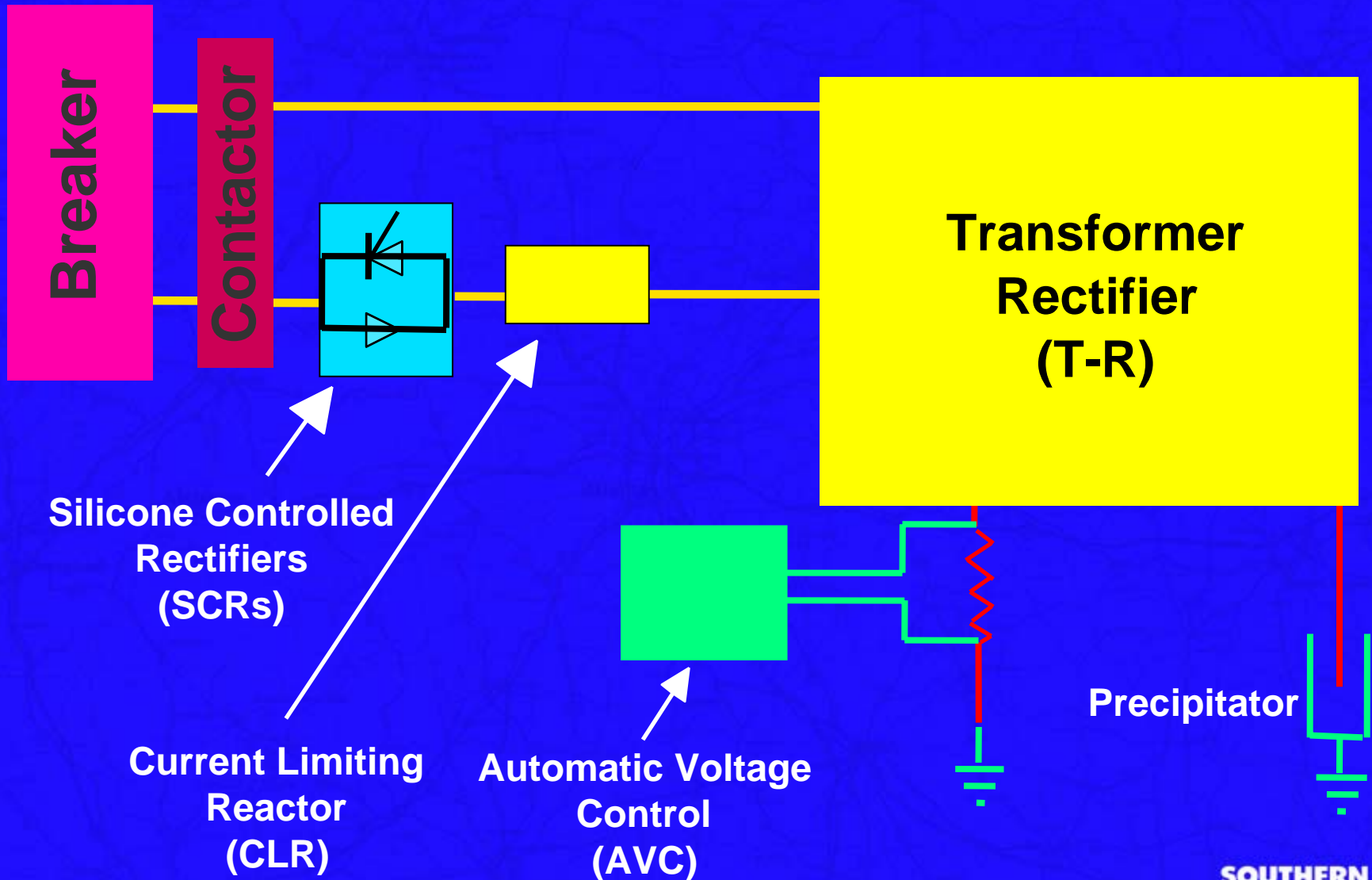

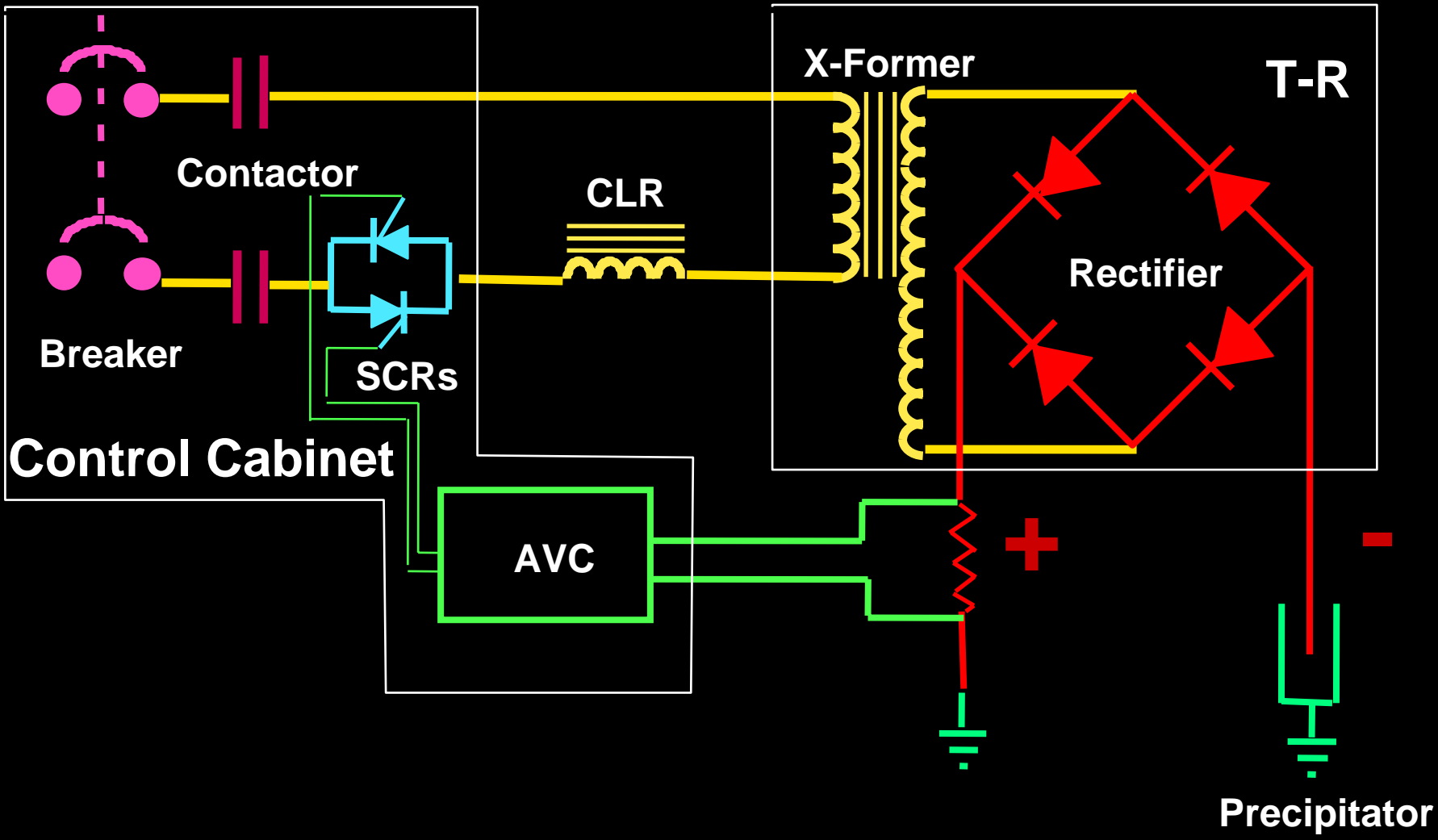

Schematic Diagram

# GVC Display and Analog Meters

Metering

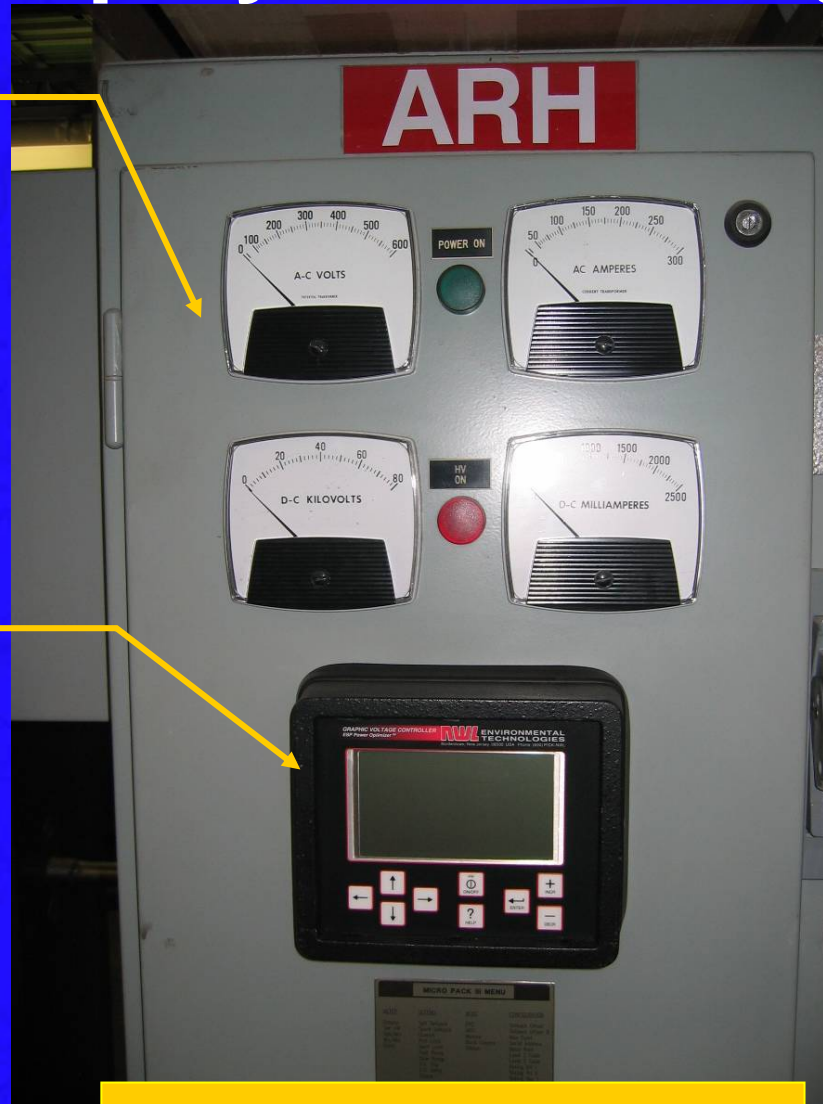

AVC HMI

The AVC Cabinet Externals

# AVC Power Components

**Main Breaker**

**AVC not  
Shown**

**Main  
Contactor  
(Starter)**

**Low Voltage  
Transformer**

**Dashpot-type  
Overload**

**Main Fuse  
and Silicon-  
Controlled  
Rectifier  
(SCR)**

**The AVC Cabinet Internals**

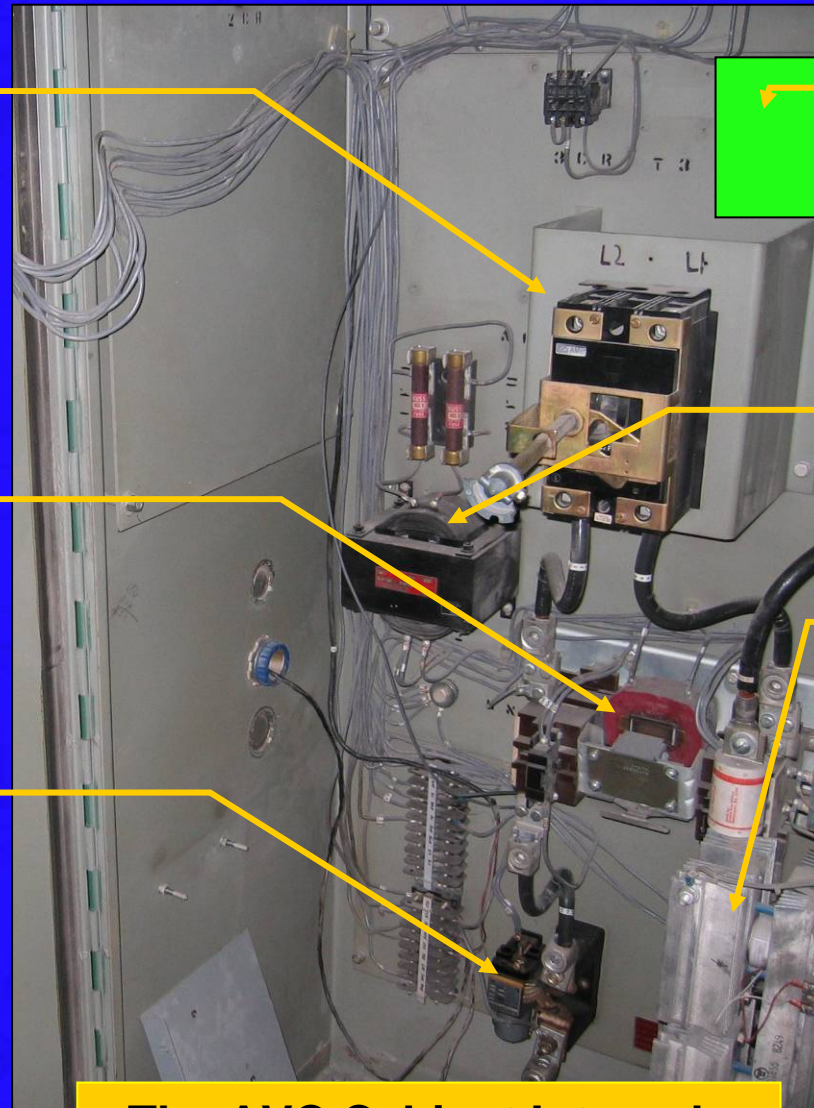

# Current Limiting Reactor (CLR)

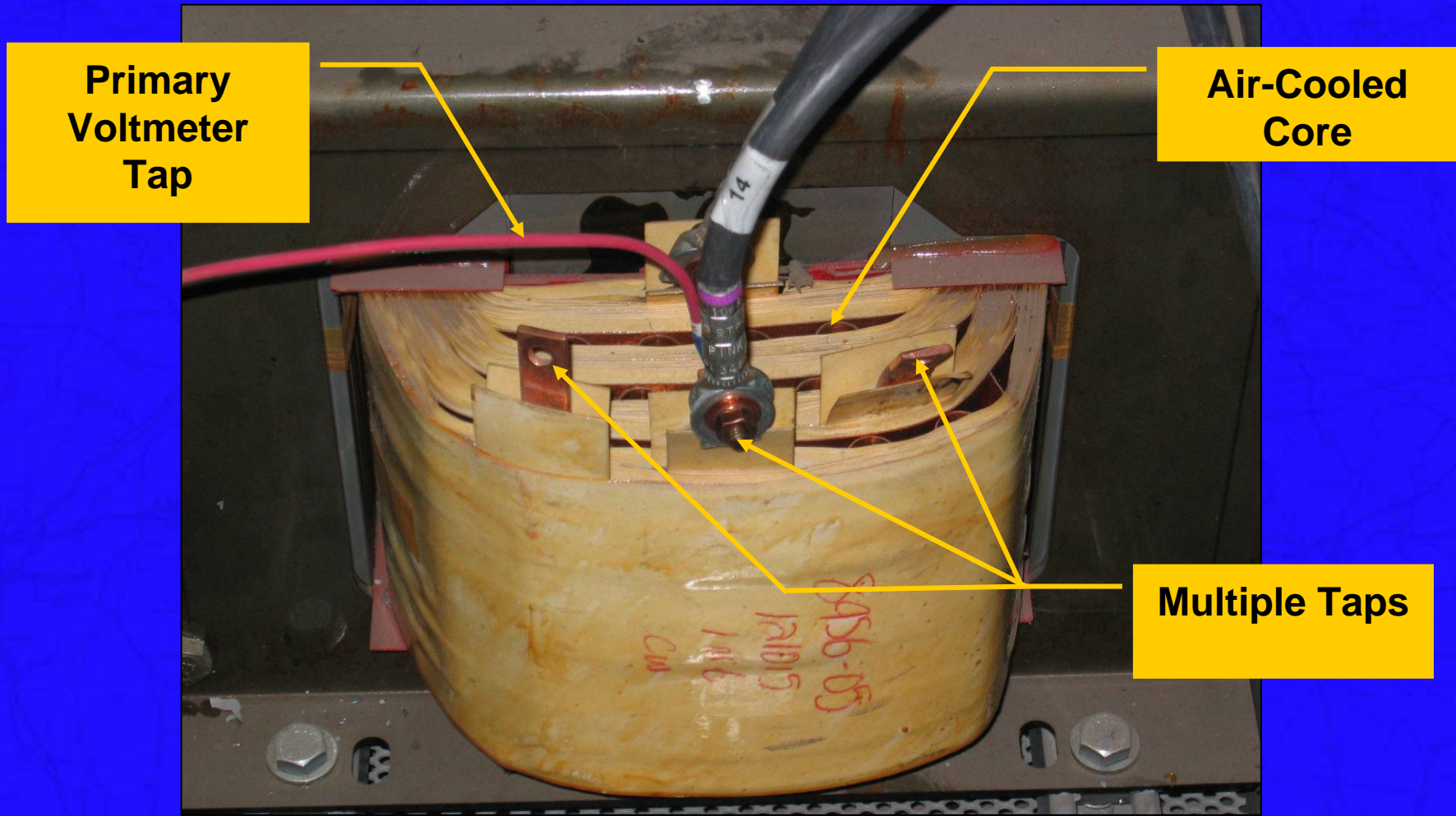

**Primary  
Voltmeter  
Tap**

**Air-Cooled  
Core**

**Multiple Taps**

**Internals of the CLR Cabinet**

# Conventional T-R Set

**Bus Duct**

**Switch Box**

**Tank**

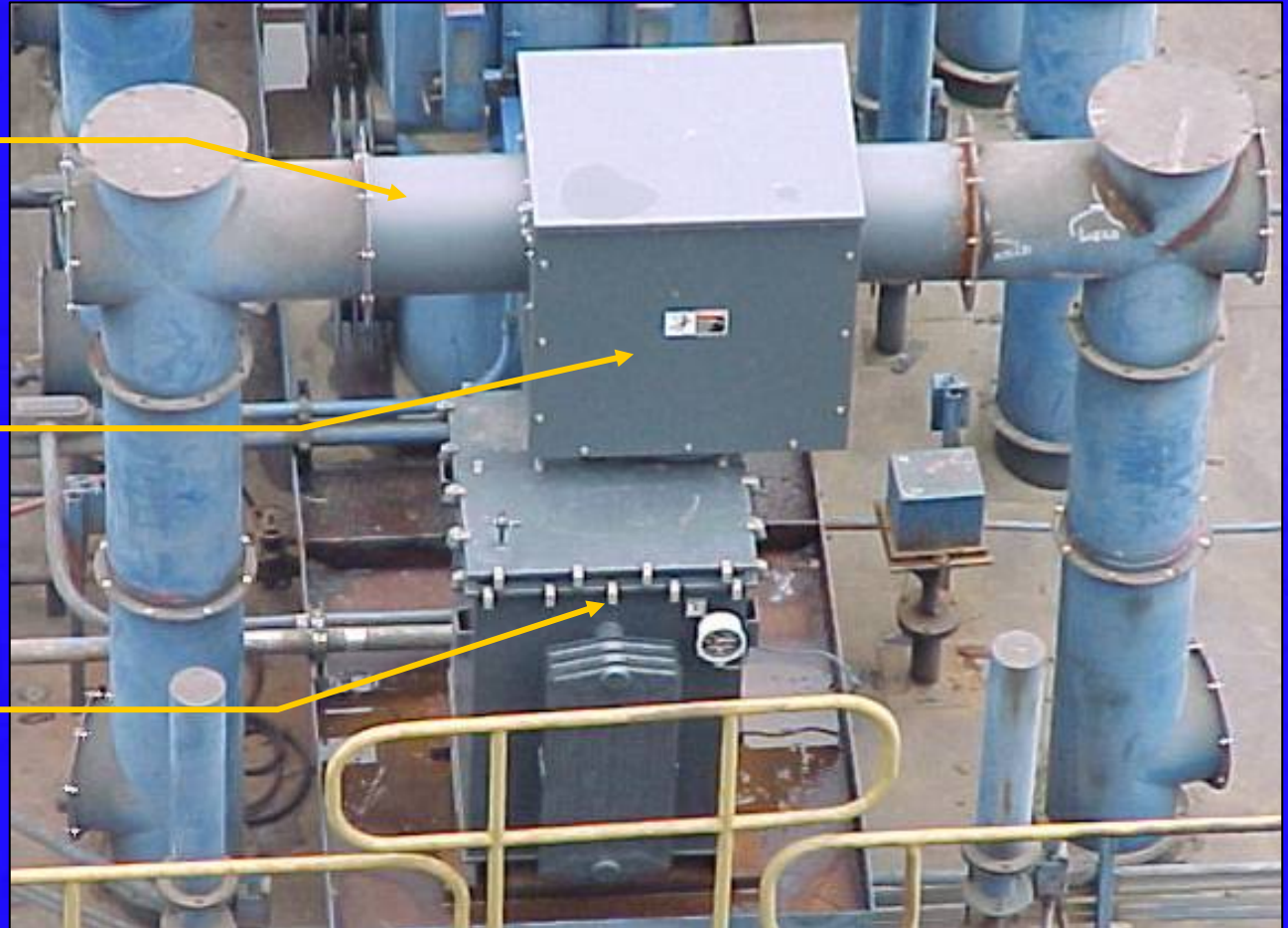

**Major Components**

# Transformer - Rectifiers

- Tank
- Core
- Rectifiers
- Choke Coils
- HV Bushings

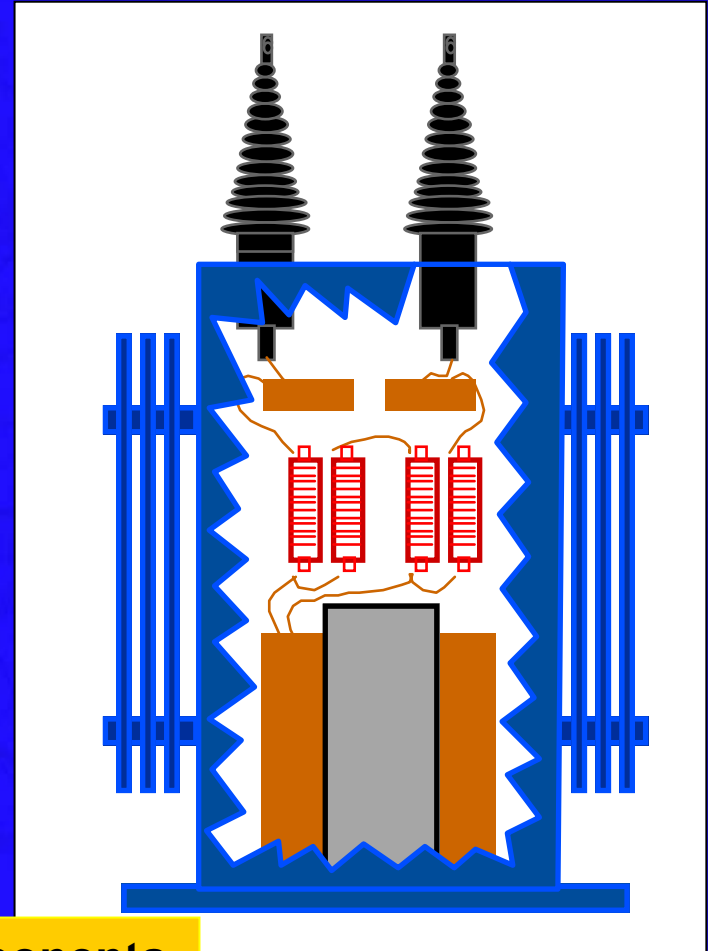

Internal Components

# Switch Mode Power Supply

**Power Supply**  
Contains: HV  
Components  
and Controls

**Switch Box**

**Bus Duct  
Connections**

**Major Components**

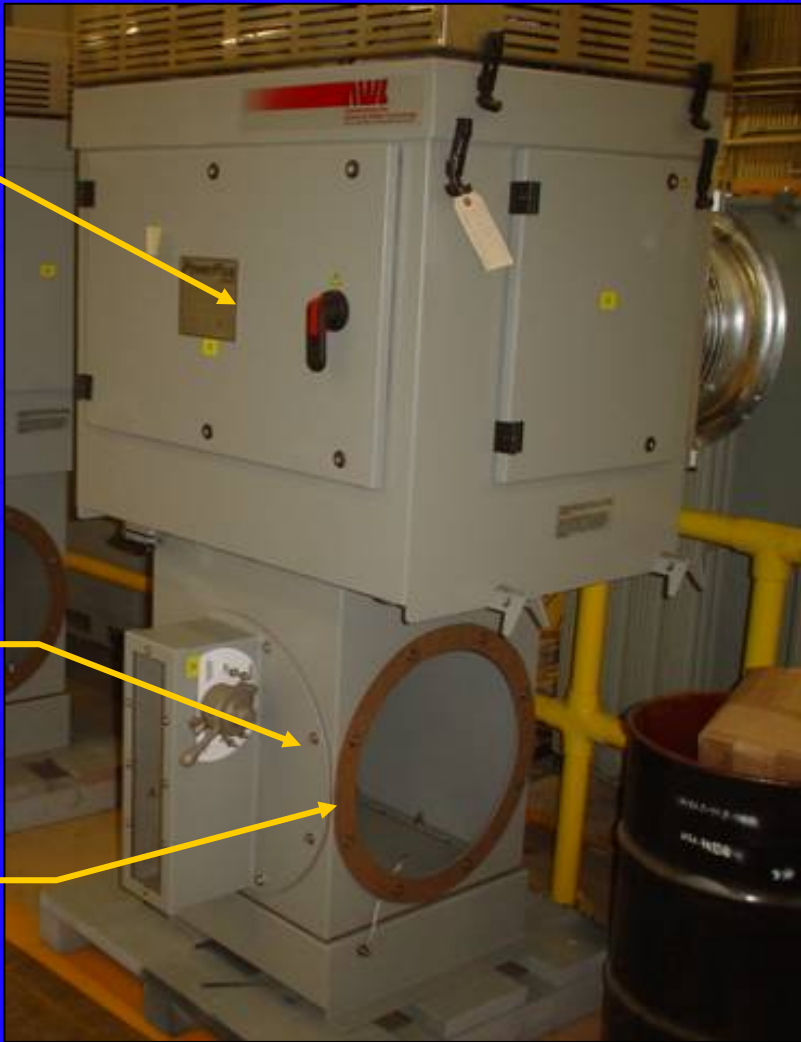

# Switch Mode Power Supply



**Installed Unit**

# NWL Switch Mode Power Supply

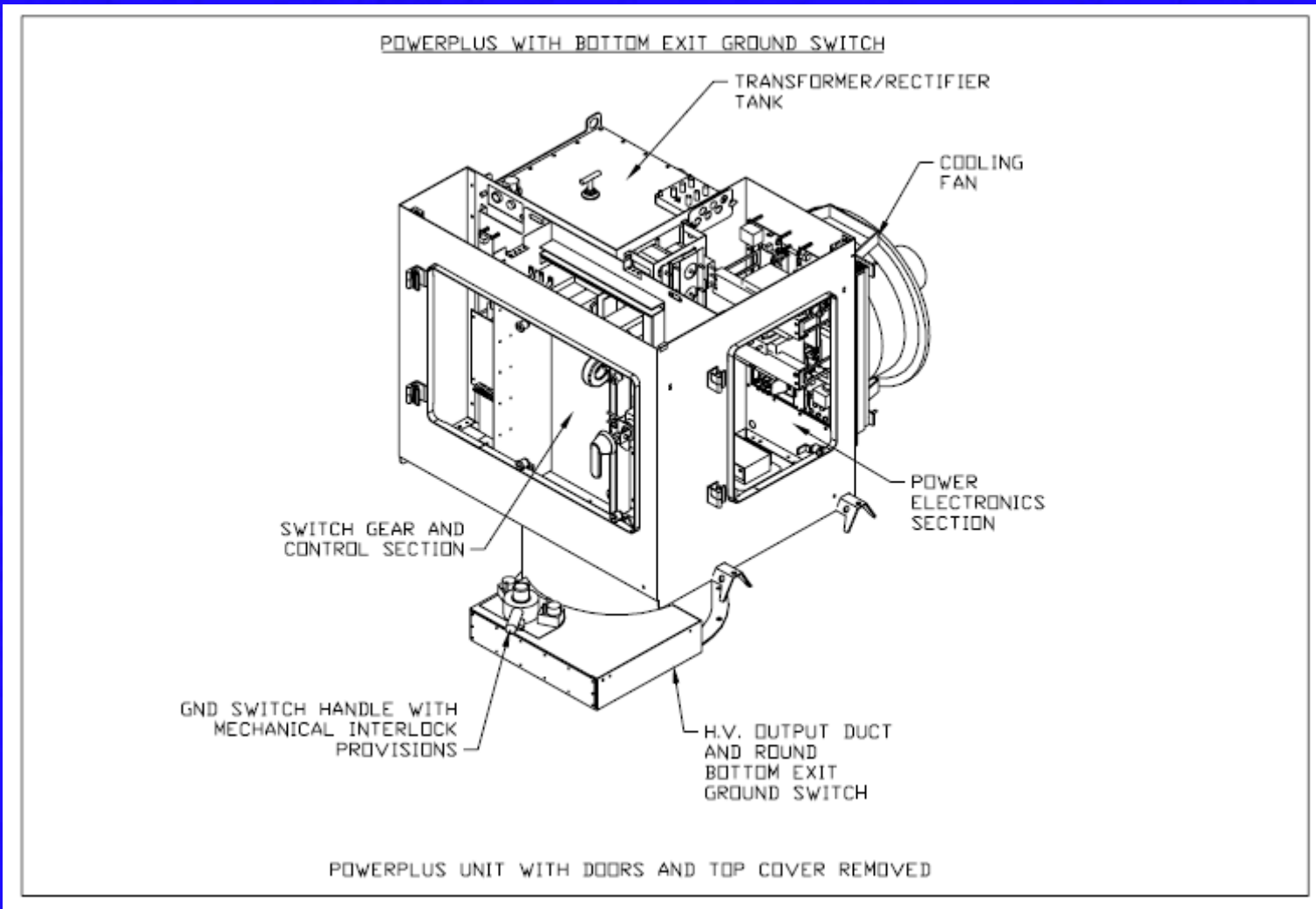

**Internal Components**

# ESP Auxiliary Systems

# Rapping Systems



# Types



**Solenoid**



**Drop Rod**



**Tumbling Hammer**

# Purge Air Blower and Heater



# SO<sub>3</sub> Conditioning System

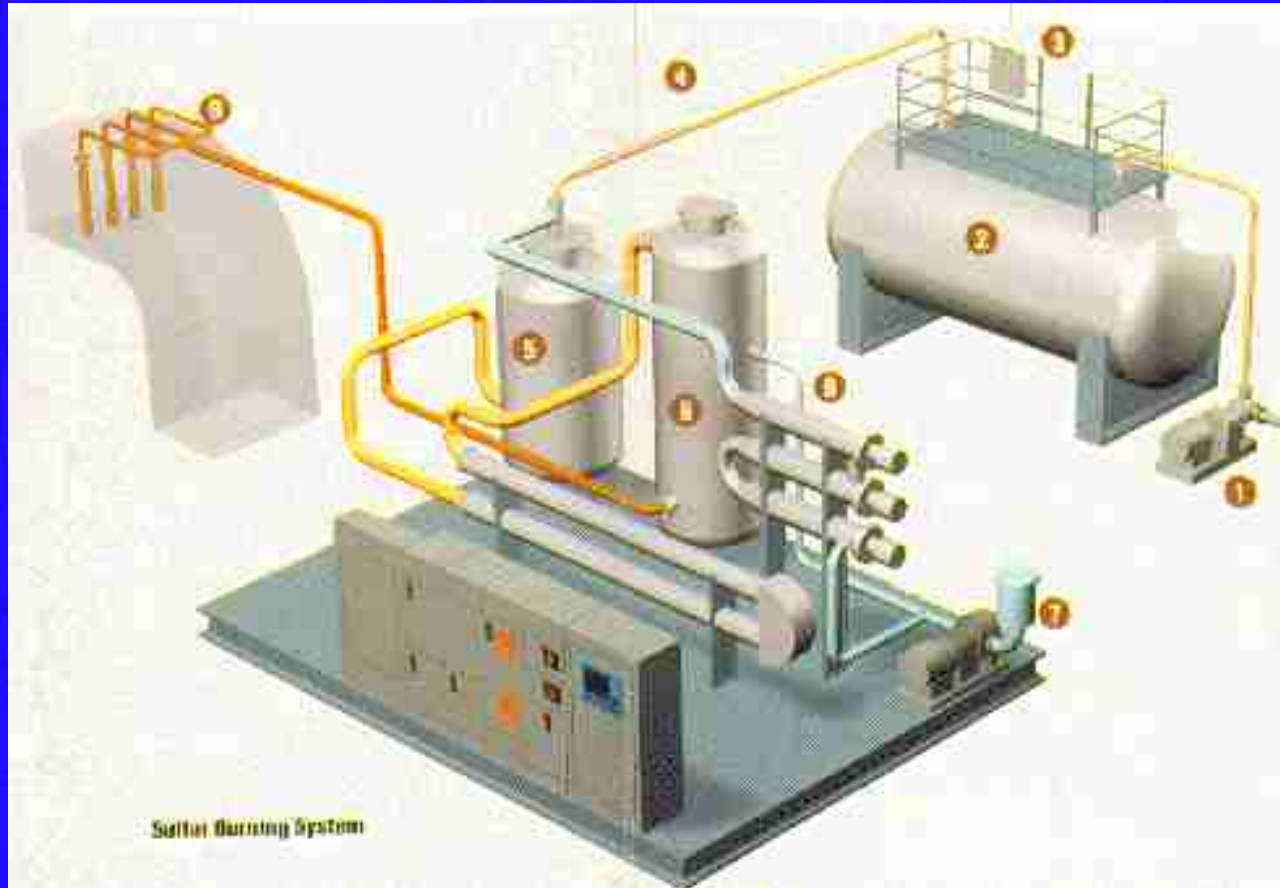

- 1 Unloading Pump
- 2 Storage Tank
- 3 Metering Pump
- 4 Liquid Sulfur at 135°C
- 5 Sulfur Burner
- 6 Multi-Stage Converter
- 7 Air Blower
- 8 Air Heater
- 9 SO<sub>3</sub>/Air at 475°C

Courtesy-Chemithon Corp.

# ESP Process

Liquefied Minerals



Condensation

Particulate

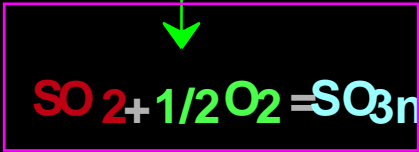

Conversion

~1%

Adsorption

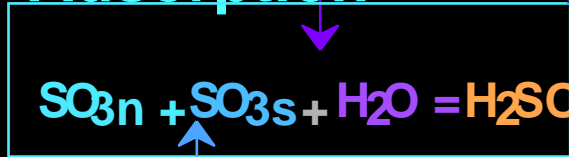

Supplemental SO<sub>3</sub>

Slip

Free SO<sub>3</sub>

Variable

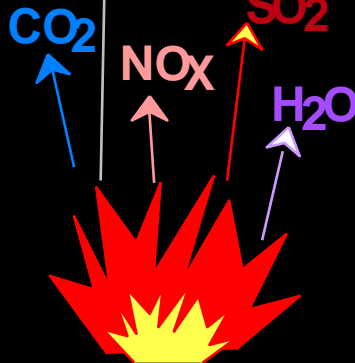

Combustion of Coal

# Cold side Conductivity

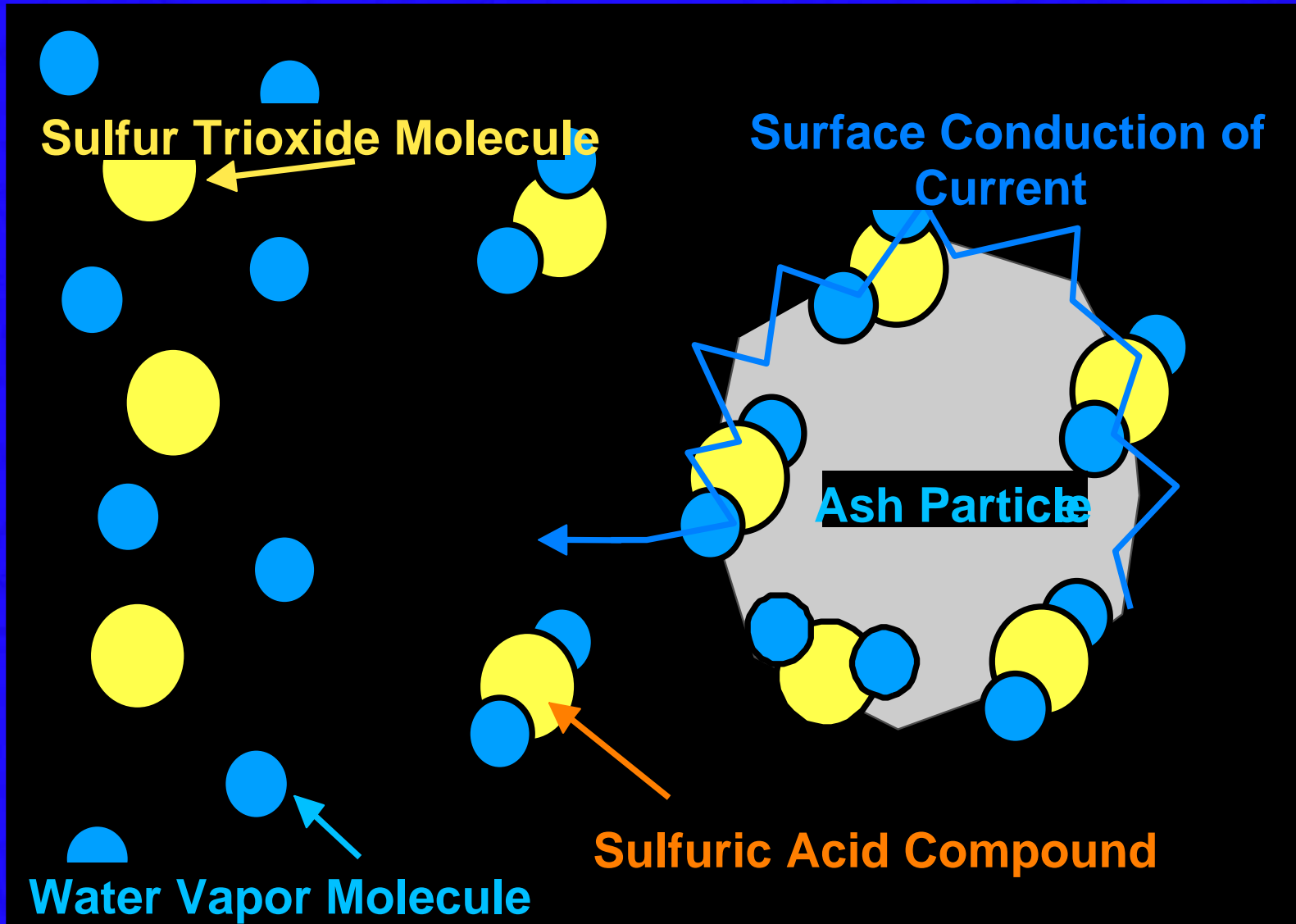

# Coldside Configuration

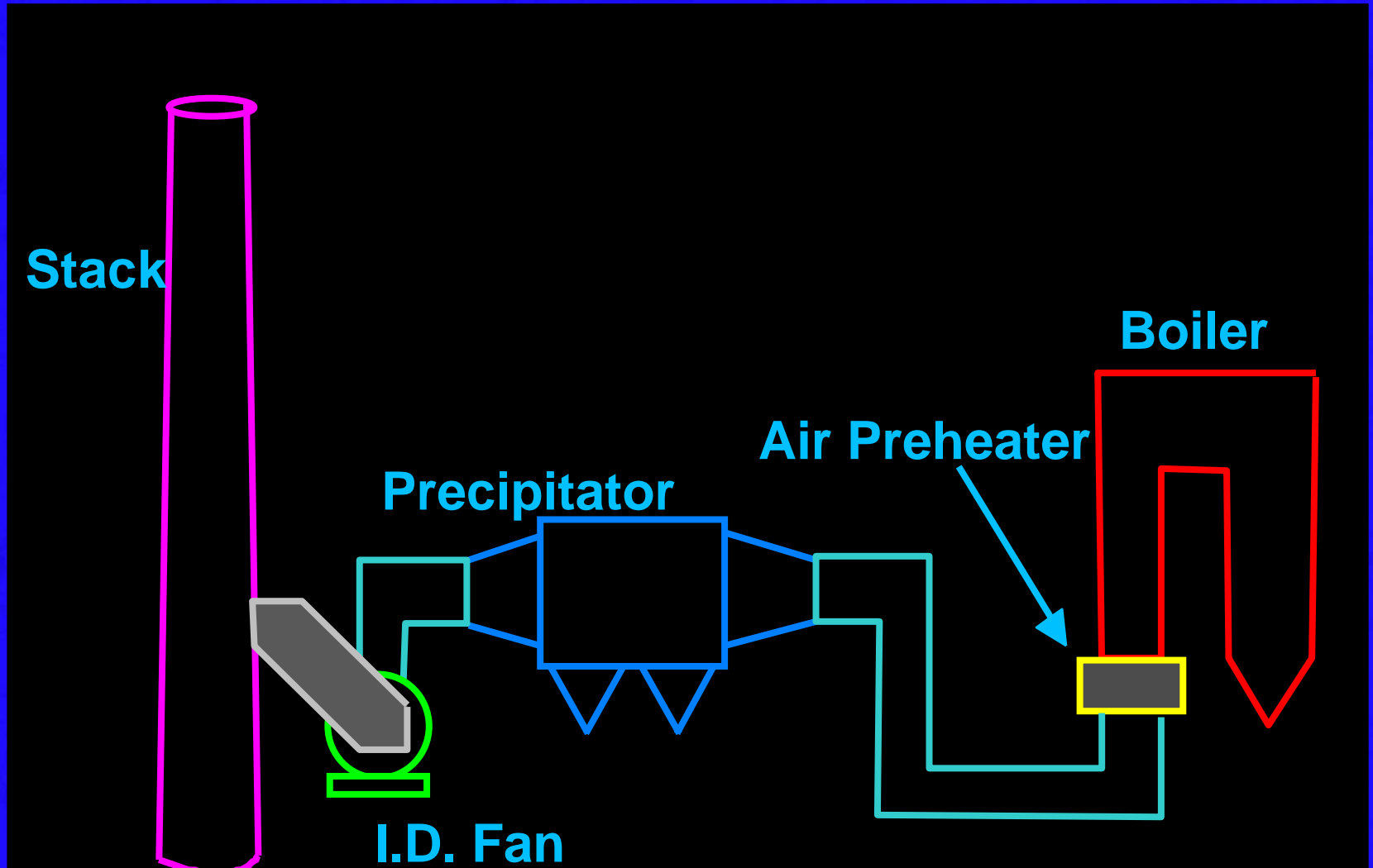

# Hotside Conductivity

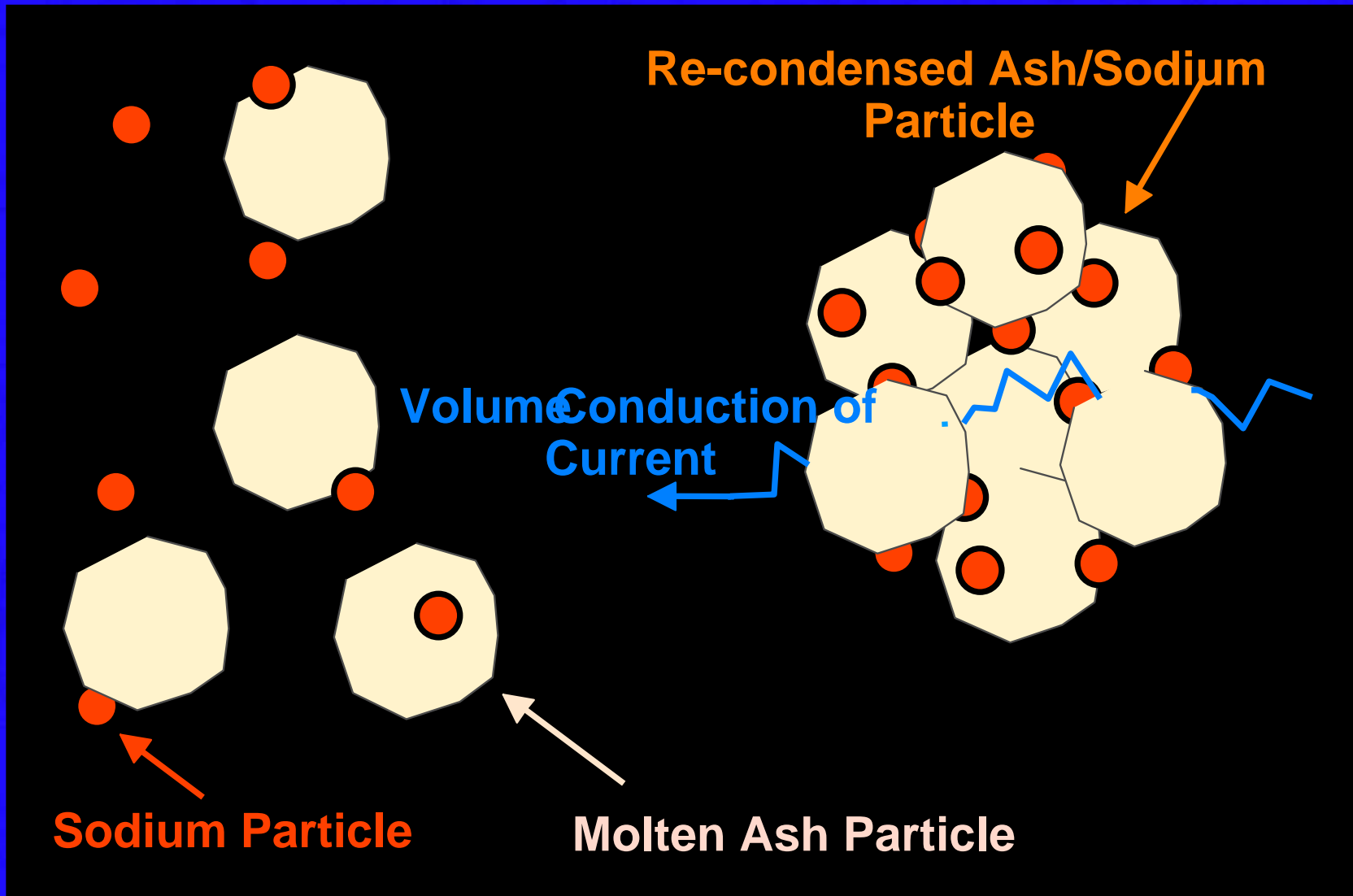



# Forces of Precipitation

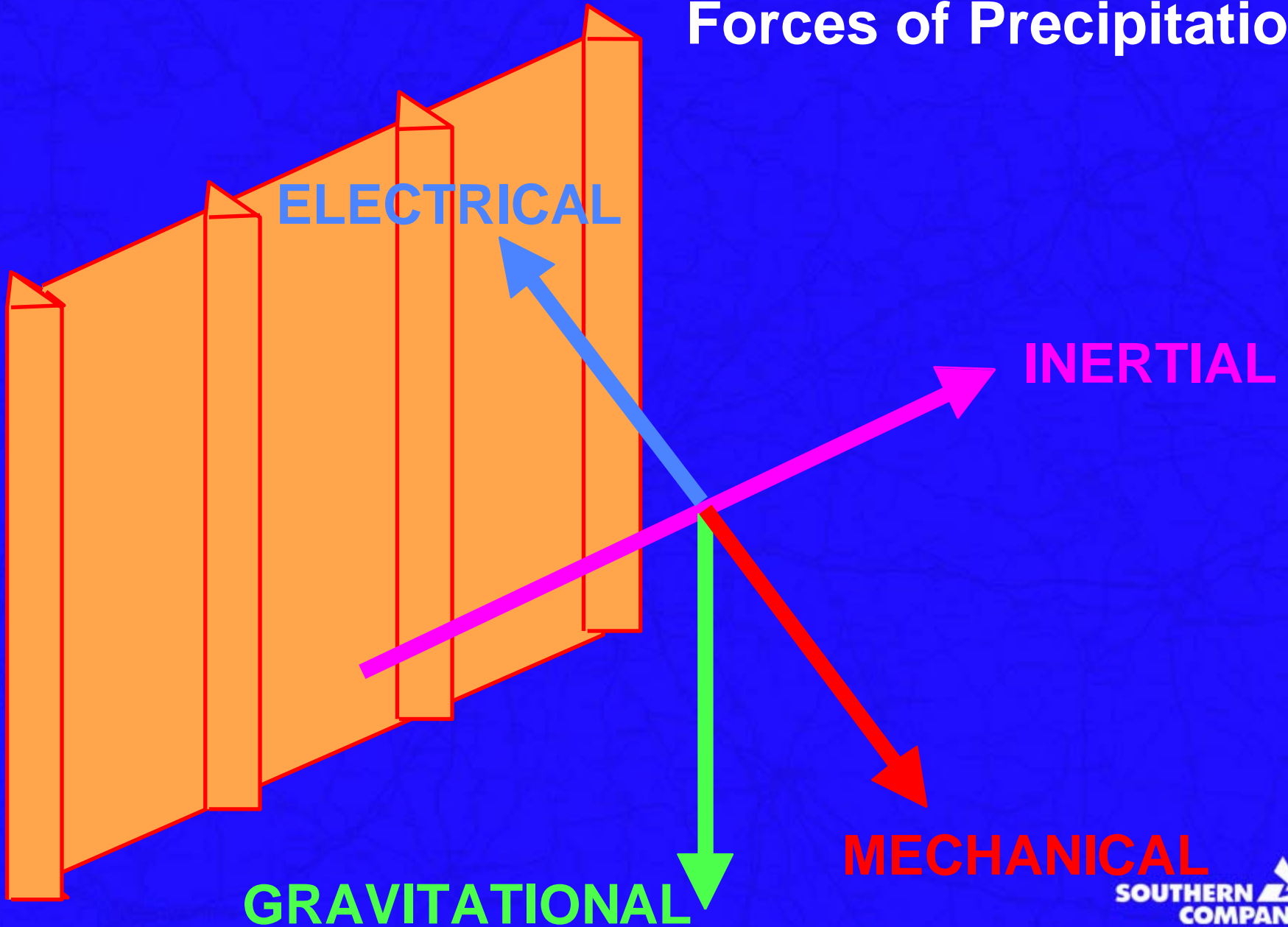

# Particle Charging

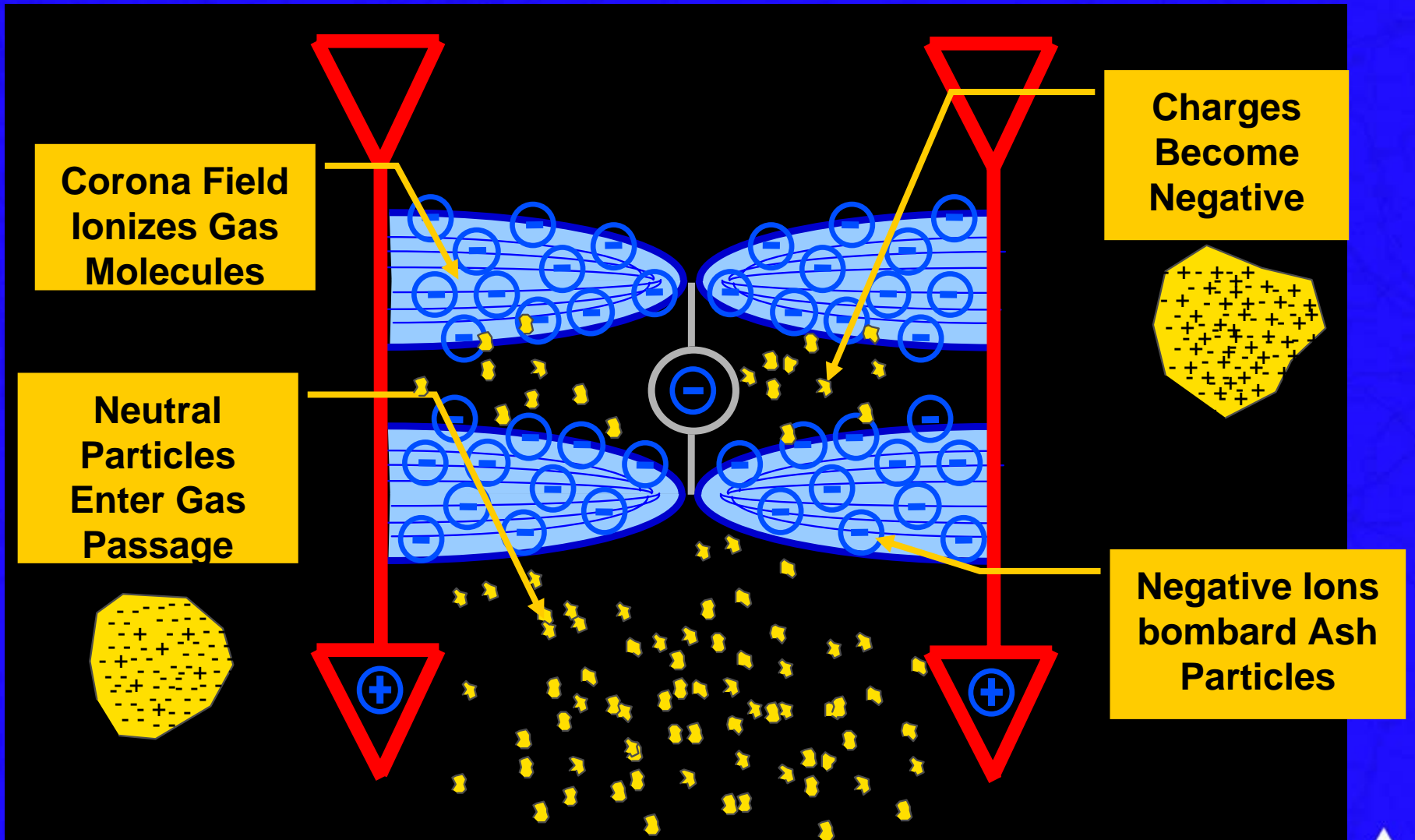

# Particle Migration

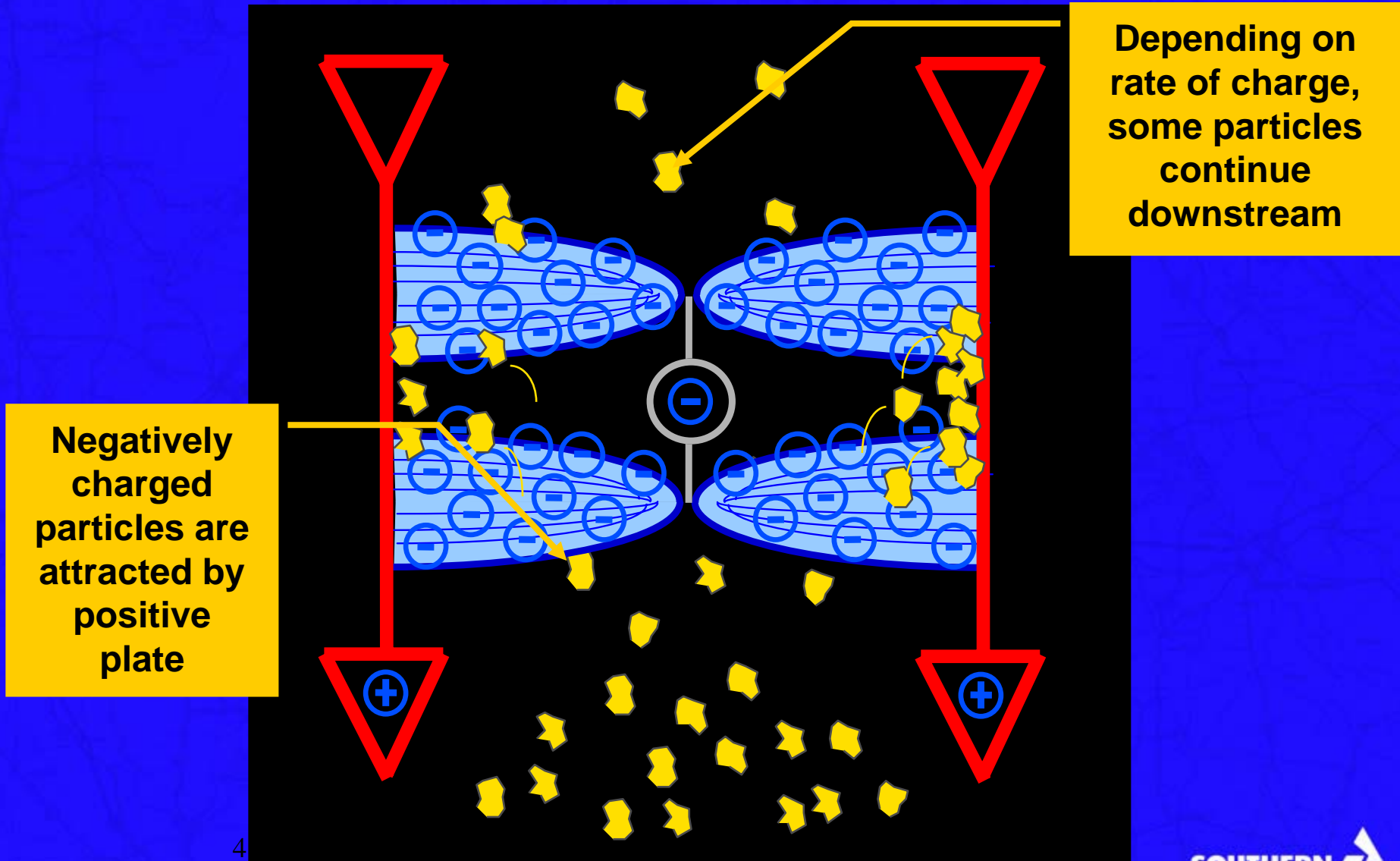

# Particle Deposition

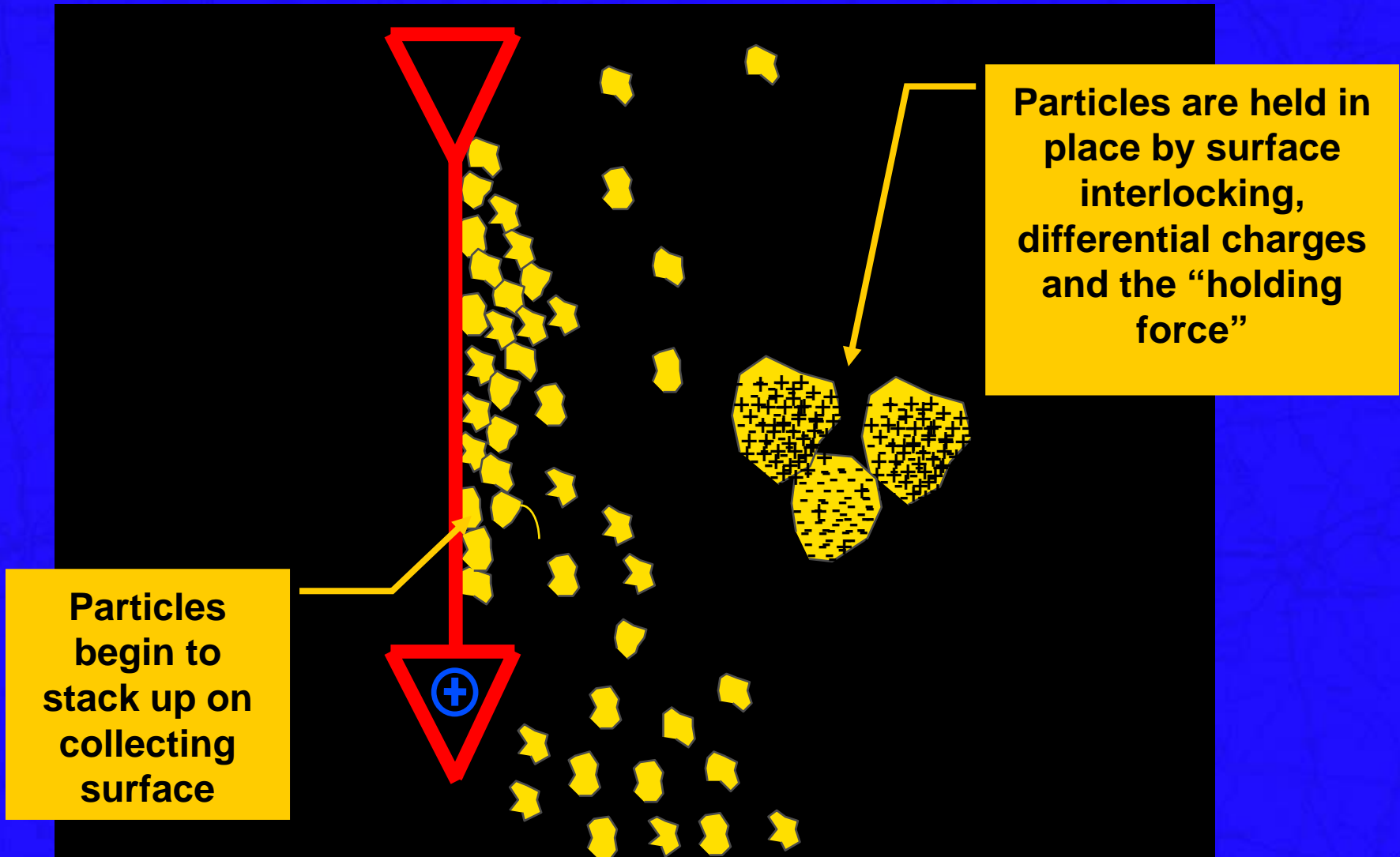

# Dustcake Release

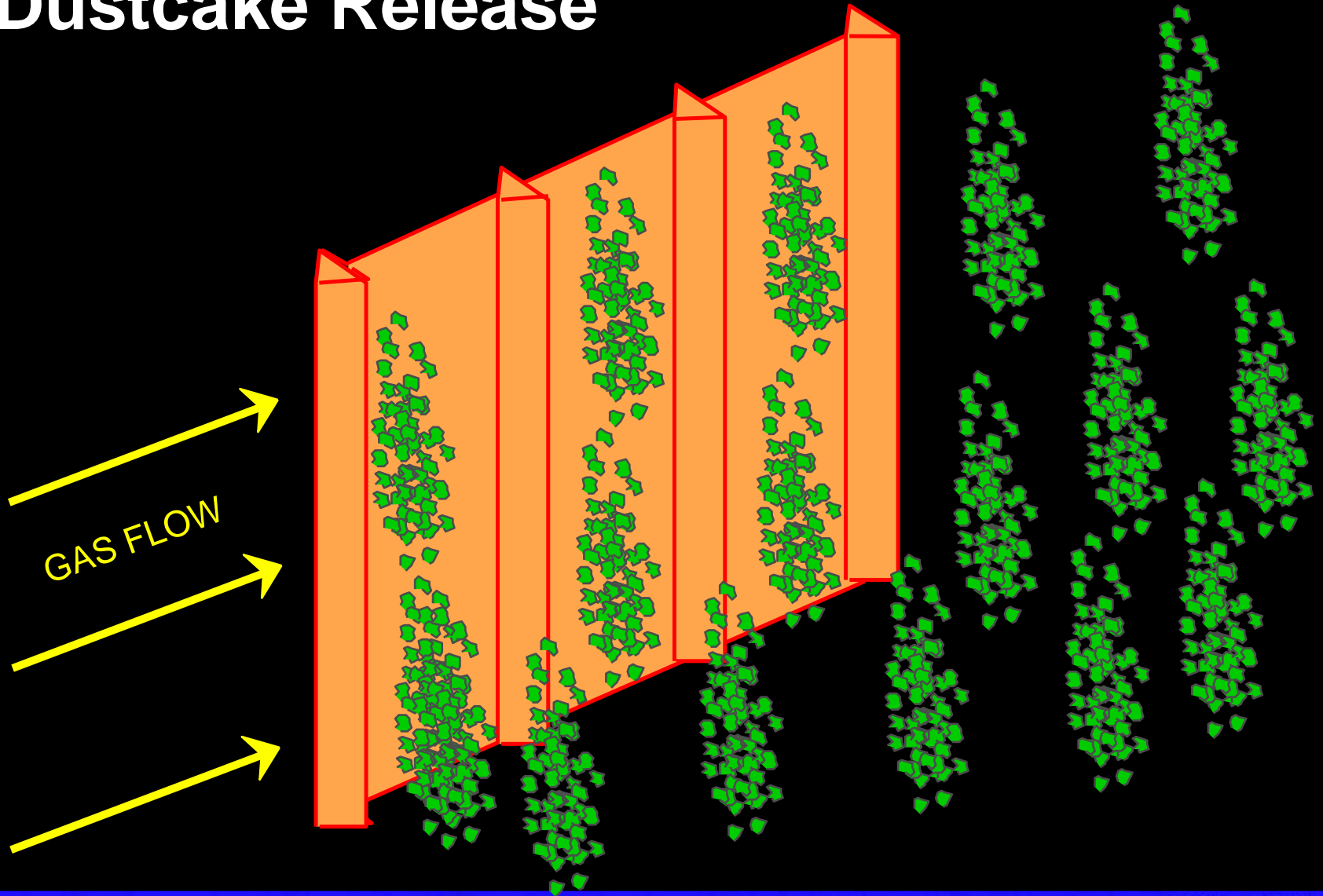

# Normal Cleaning

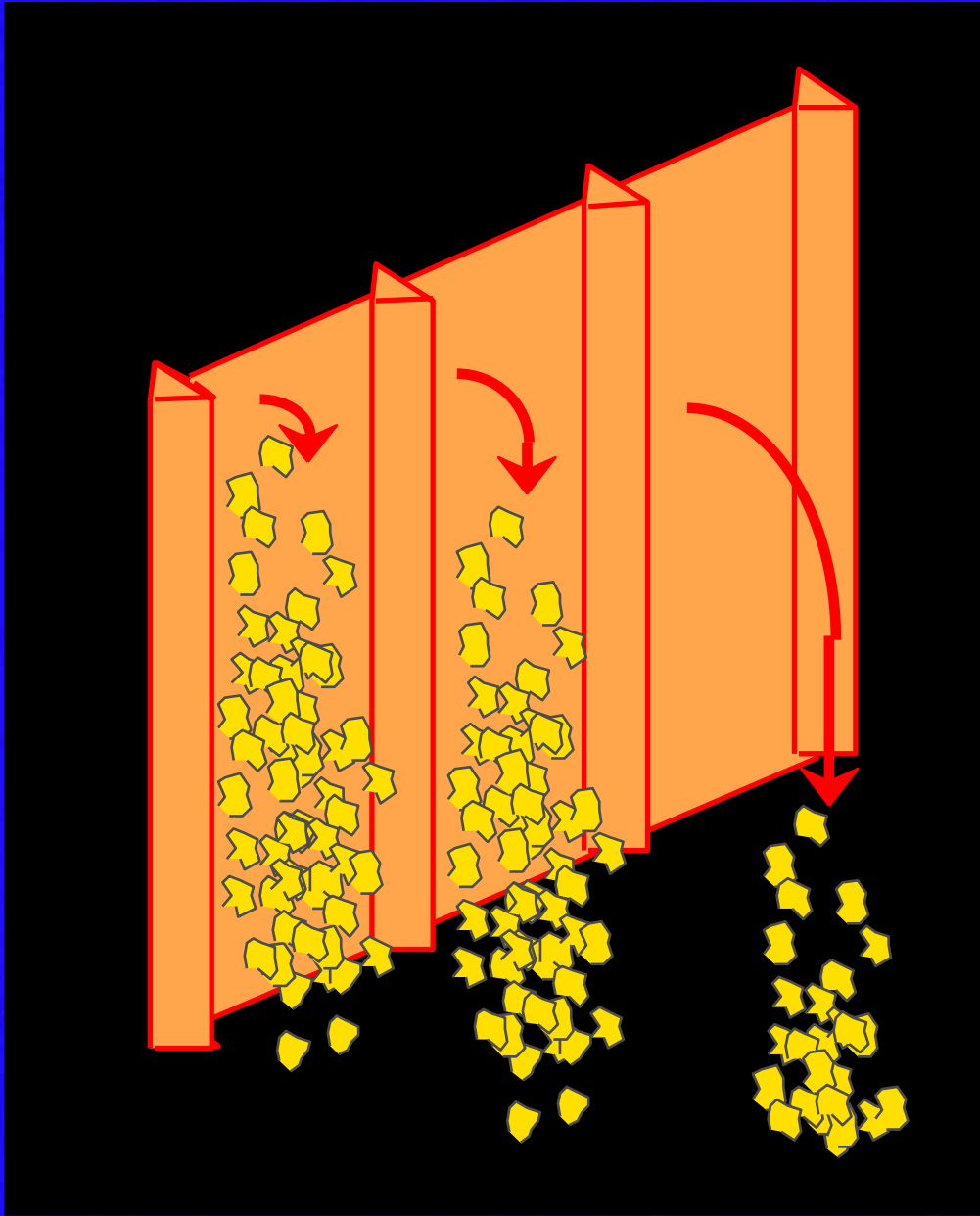

# High Re-entrainment

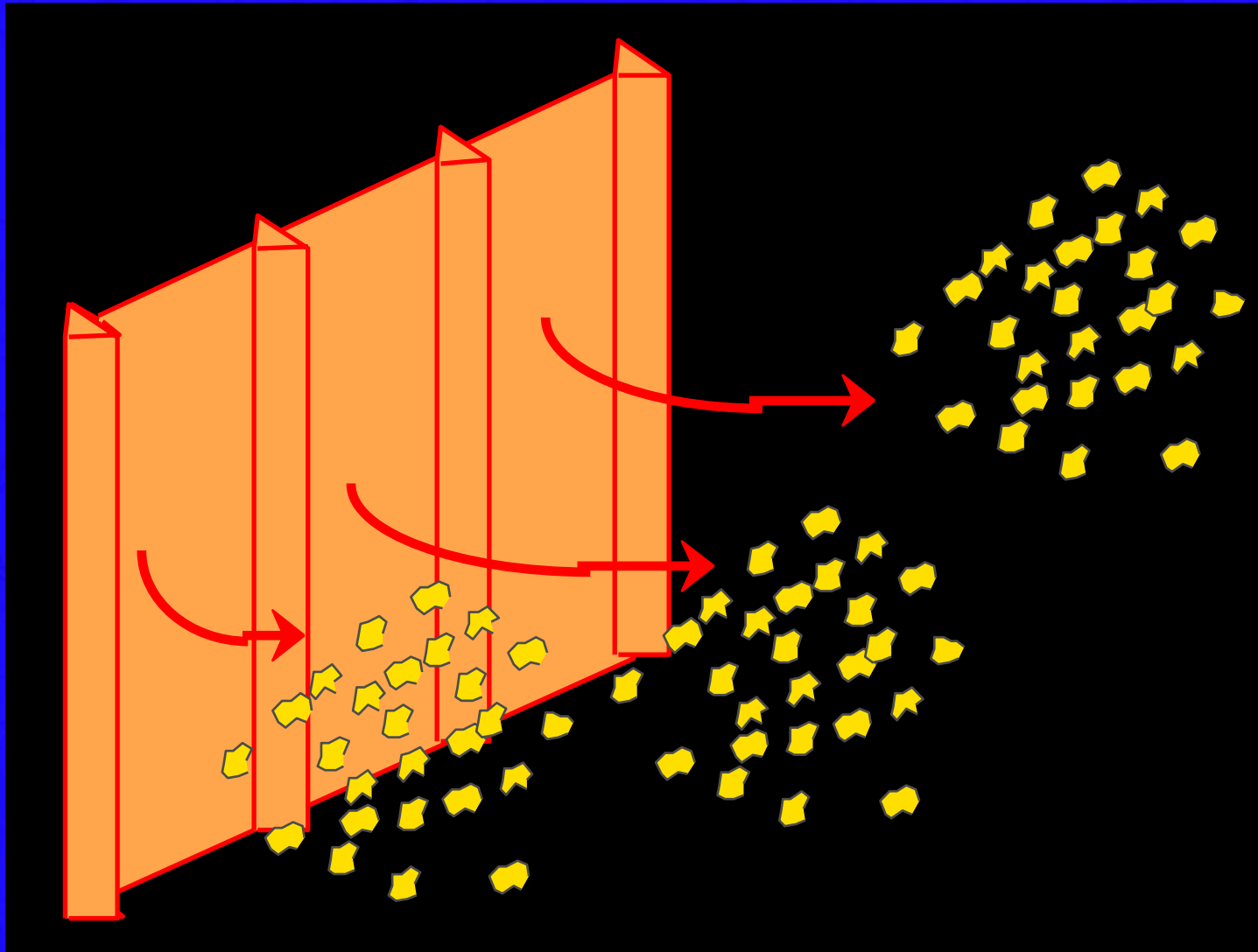

# Abnormal Cleaning



# Particle Trajectory

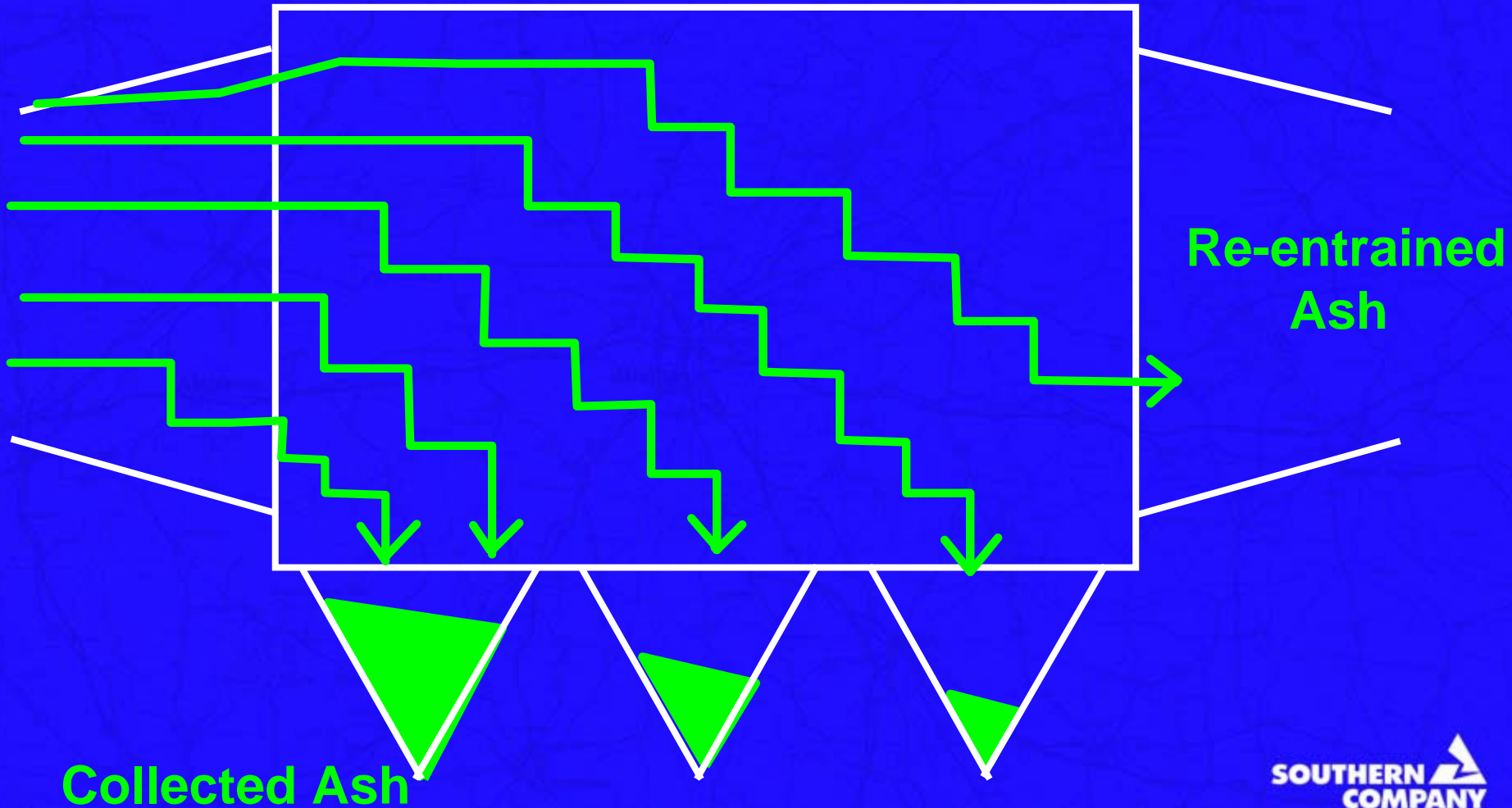

# Fractional Collection

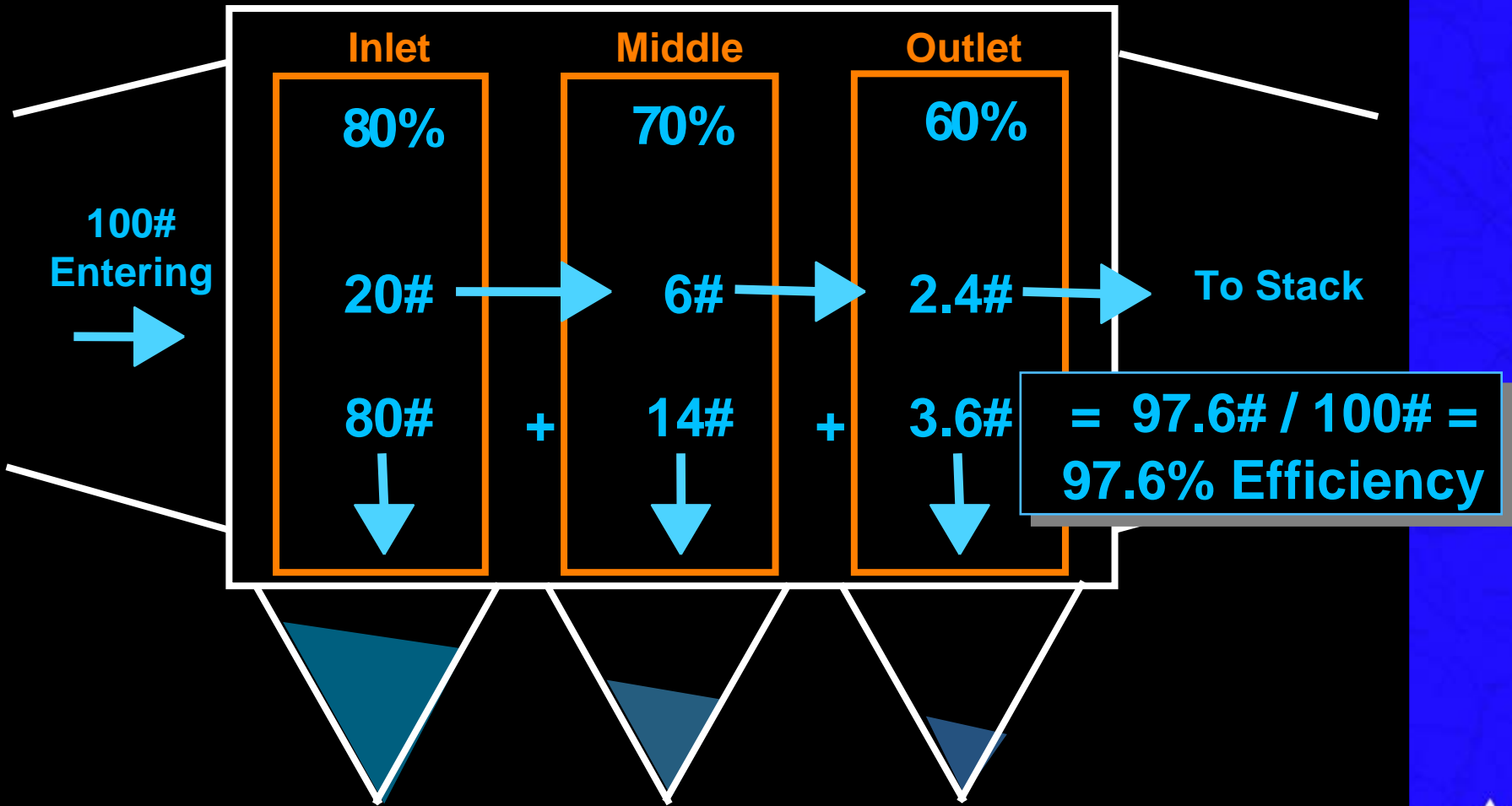

# ESP Electrical Effects

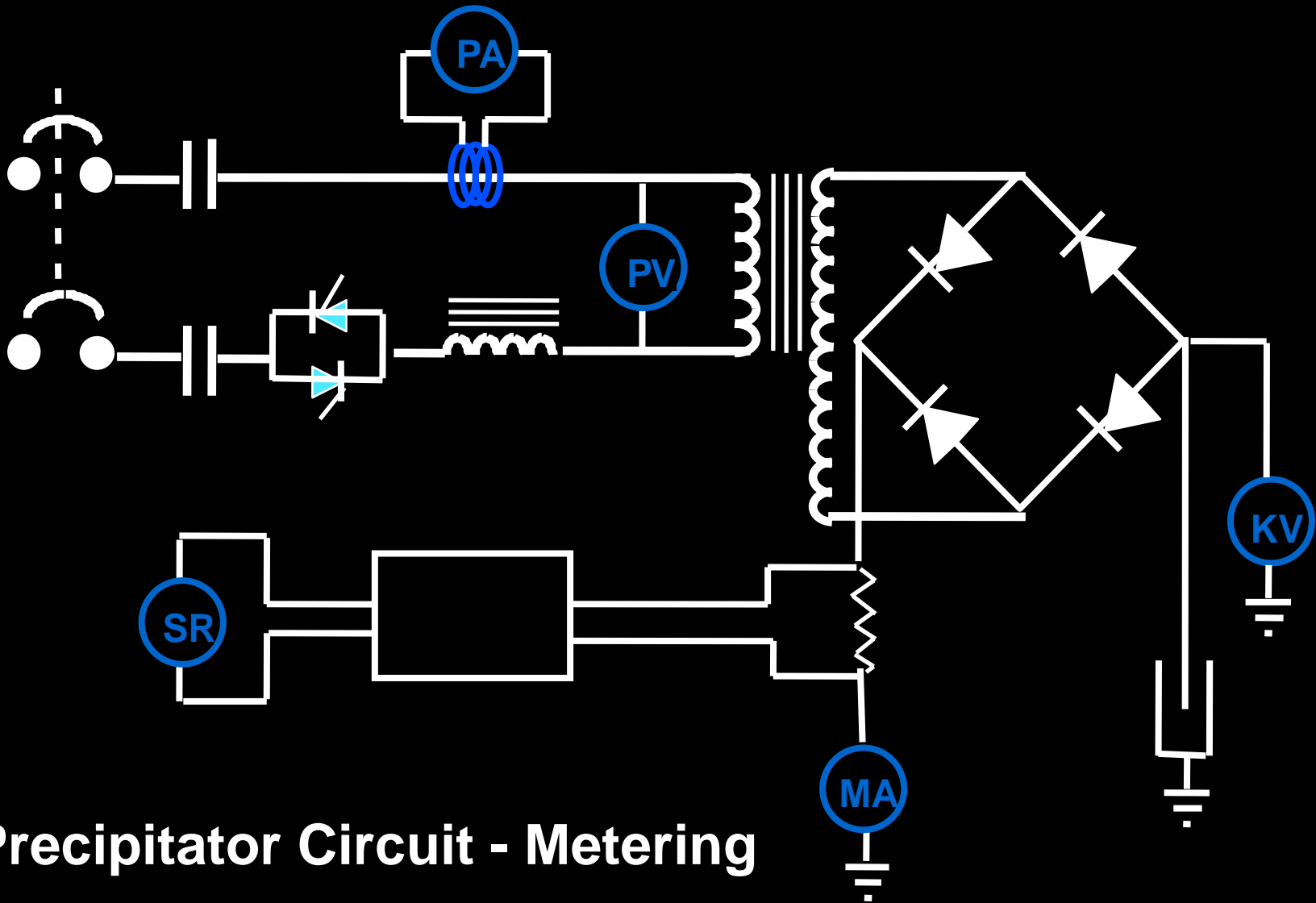

**Precipitator Circuit - Metering**

# Inlet Fields

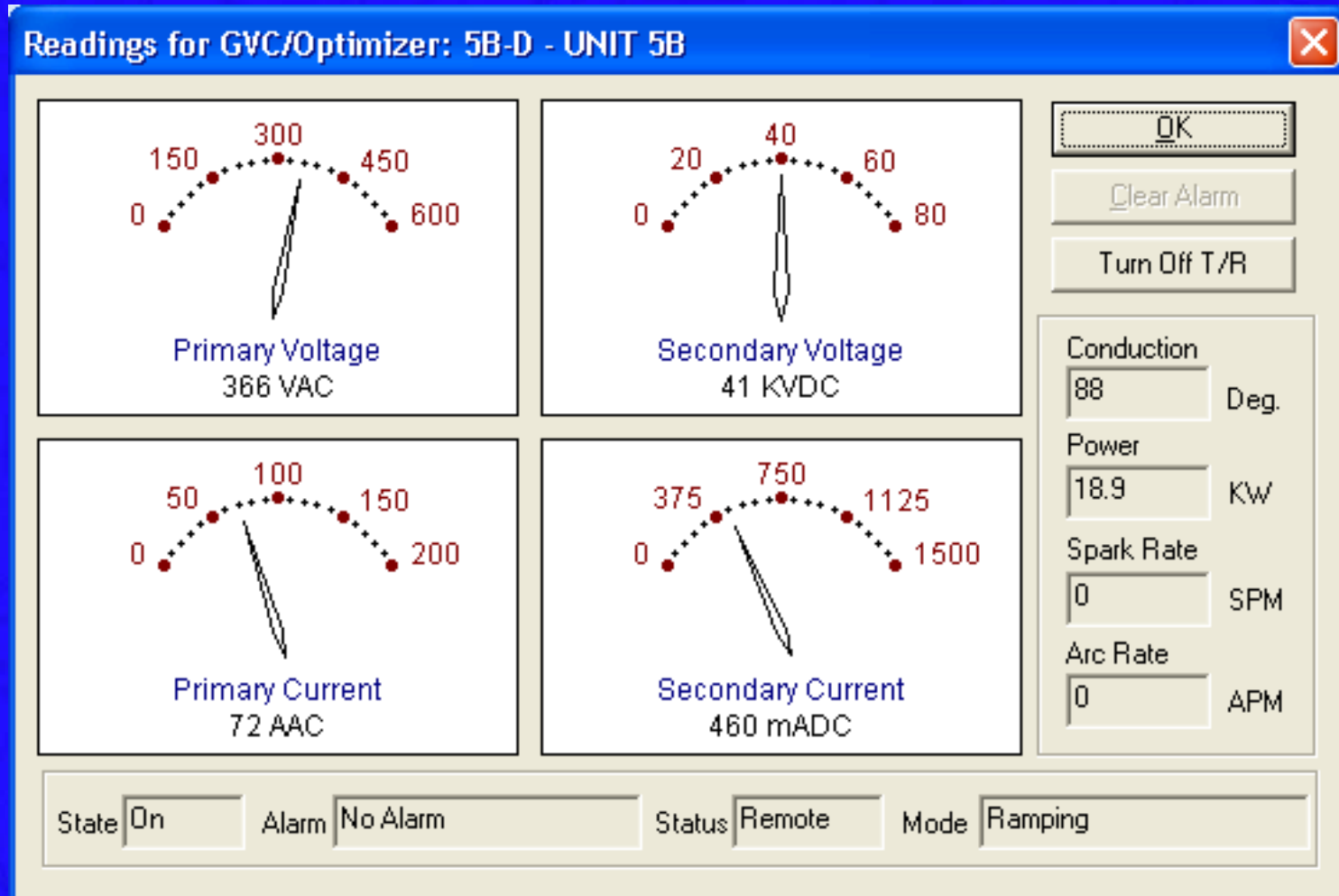

**High Secondary Voltage: 40 – 60 KV**

**Low to Medium Secondary Current: 150 – 500 mA**

**Higher Spark and Arc Rates: 30 – 60 SPM**

# Outlet Fields

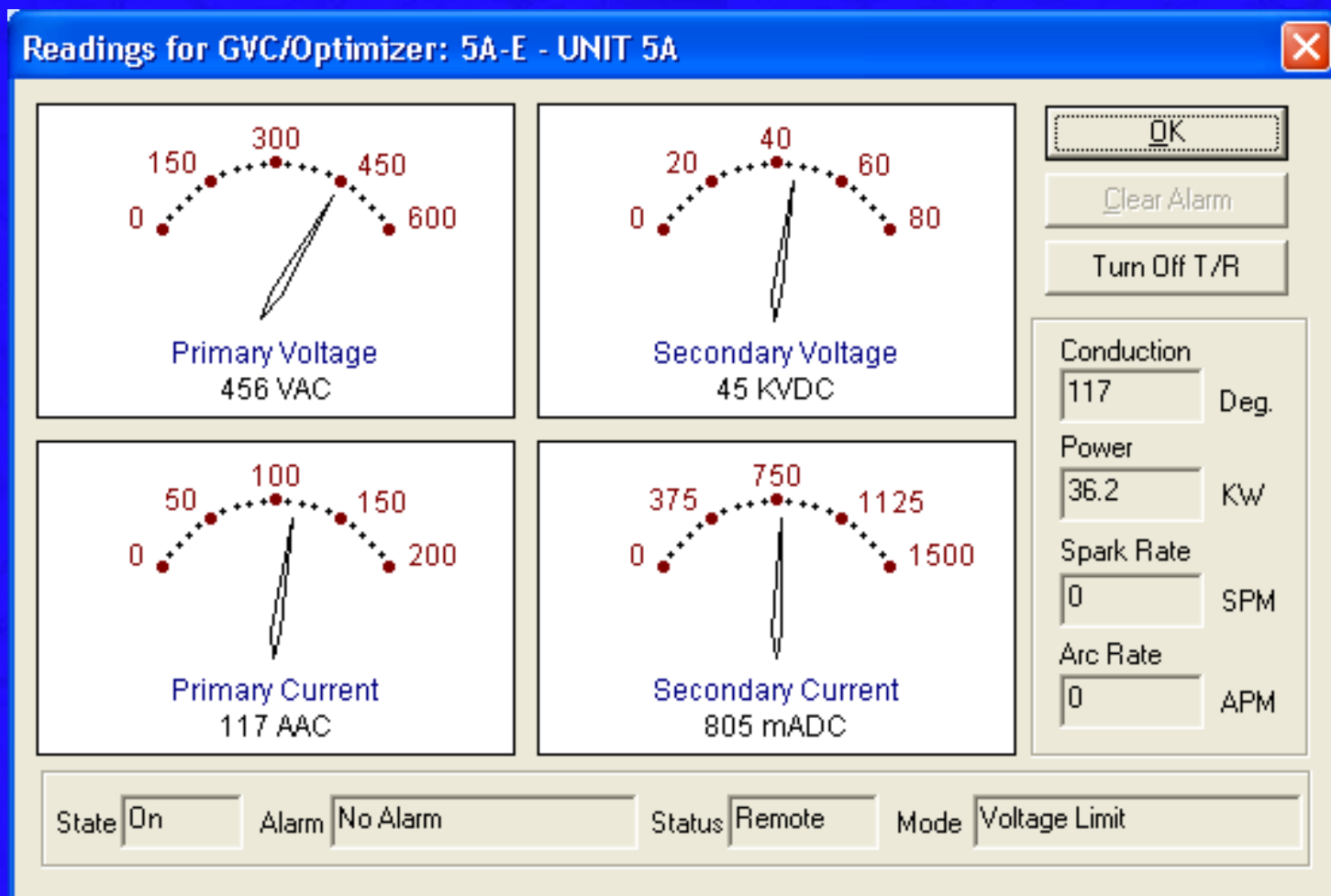

**Medium Secondary Voltage : 35 – 55 KV**  
**High Secondary Current: 500 – 1500 mA**  
**Minimum Sparks and Arcs: 0 – 5 SPM**

# All Fields with Energy Management ON

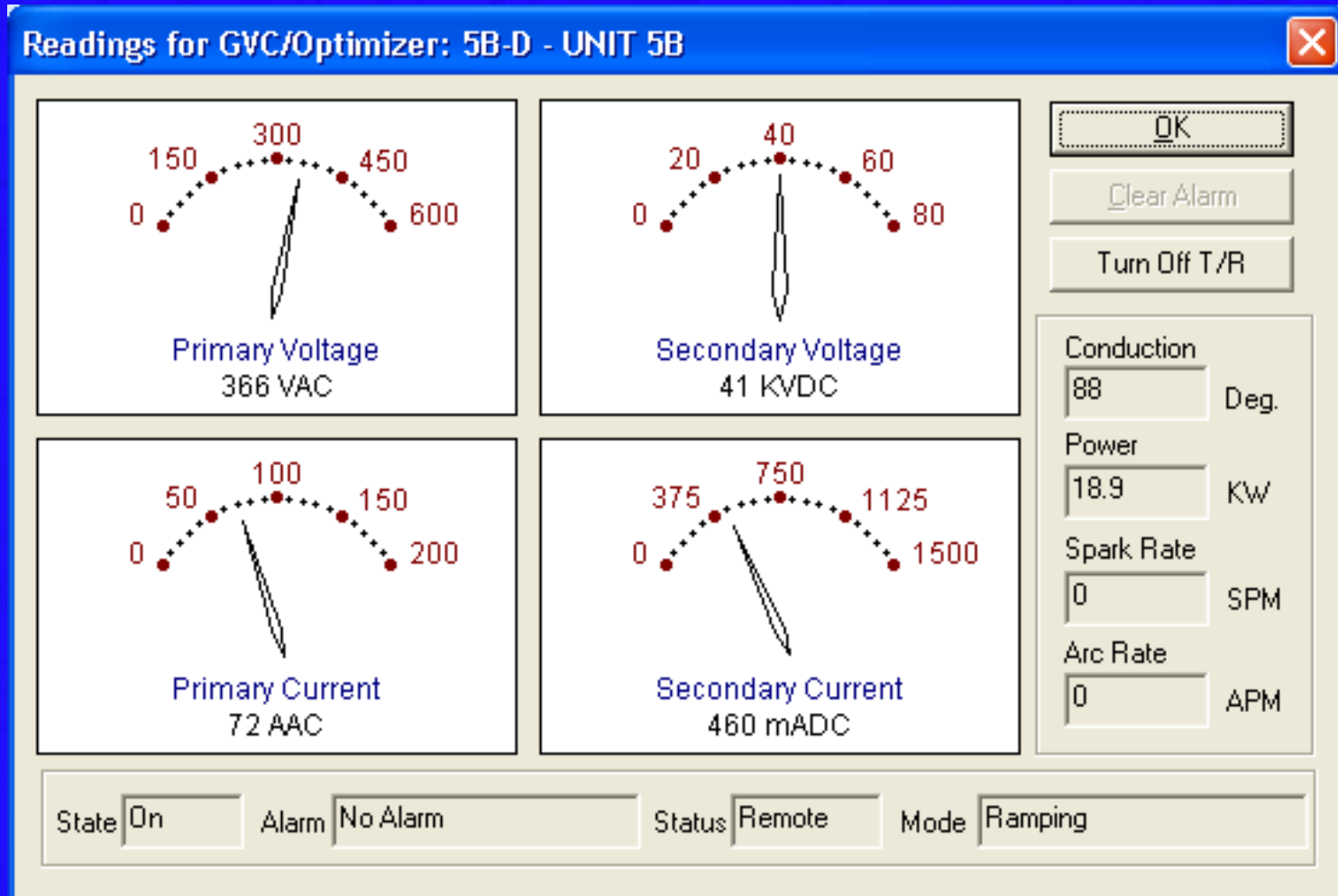

**Reduced Secondary Voltage : 35 – 50 KV**

**Reduced Secondary Current: 150 – 500 mA**

**Minimum Sparks and Arcs: 0 – 5 SPM**

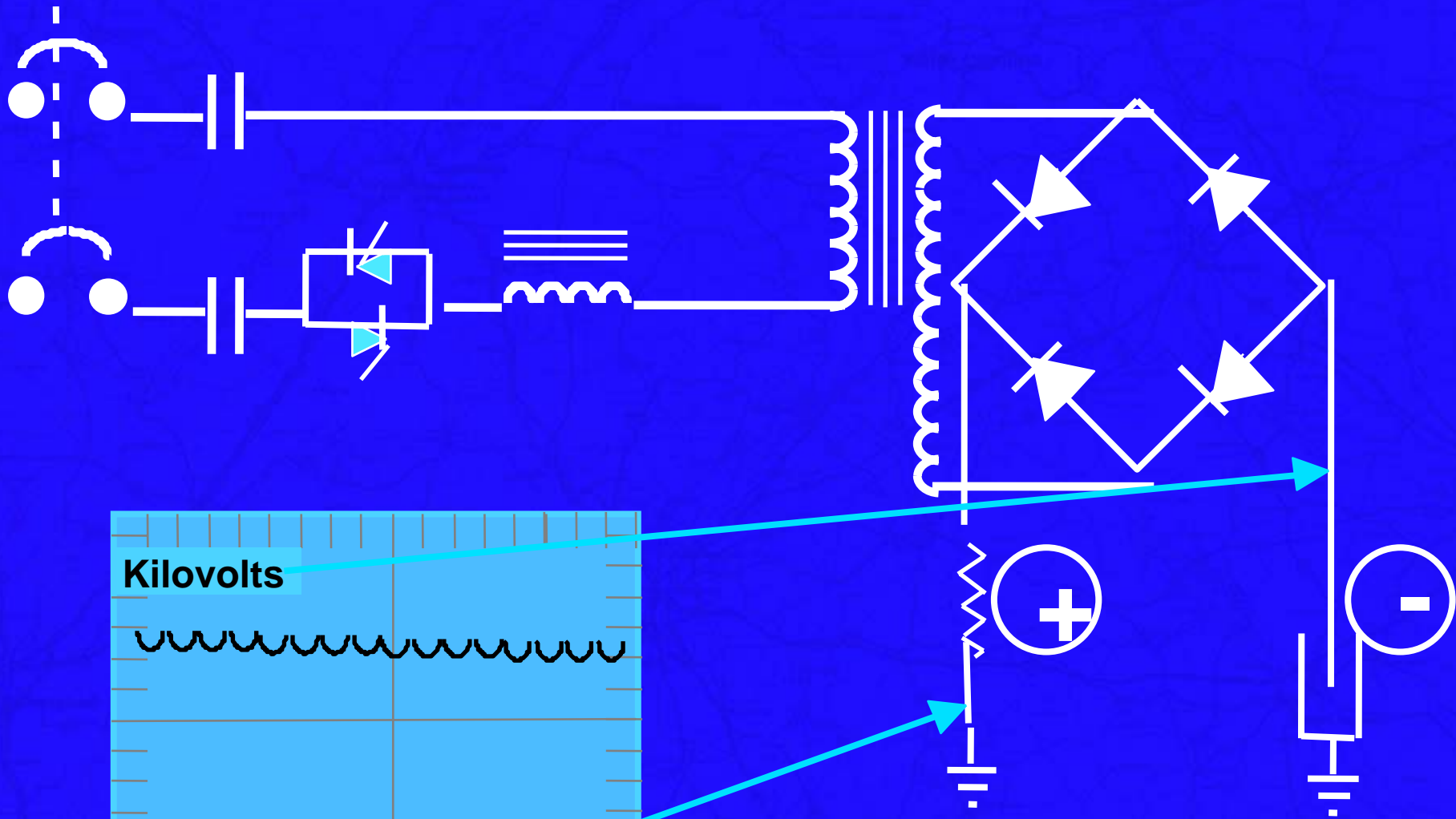

Kilovolts



Milliamps

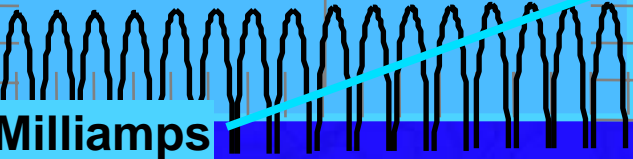

# Precipitator Circuit - Waveforms

# Normal Operation

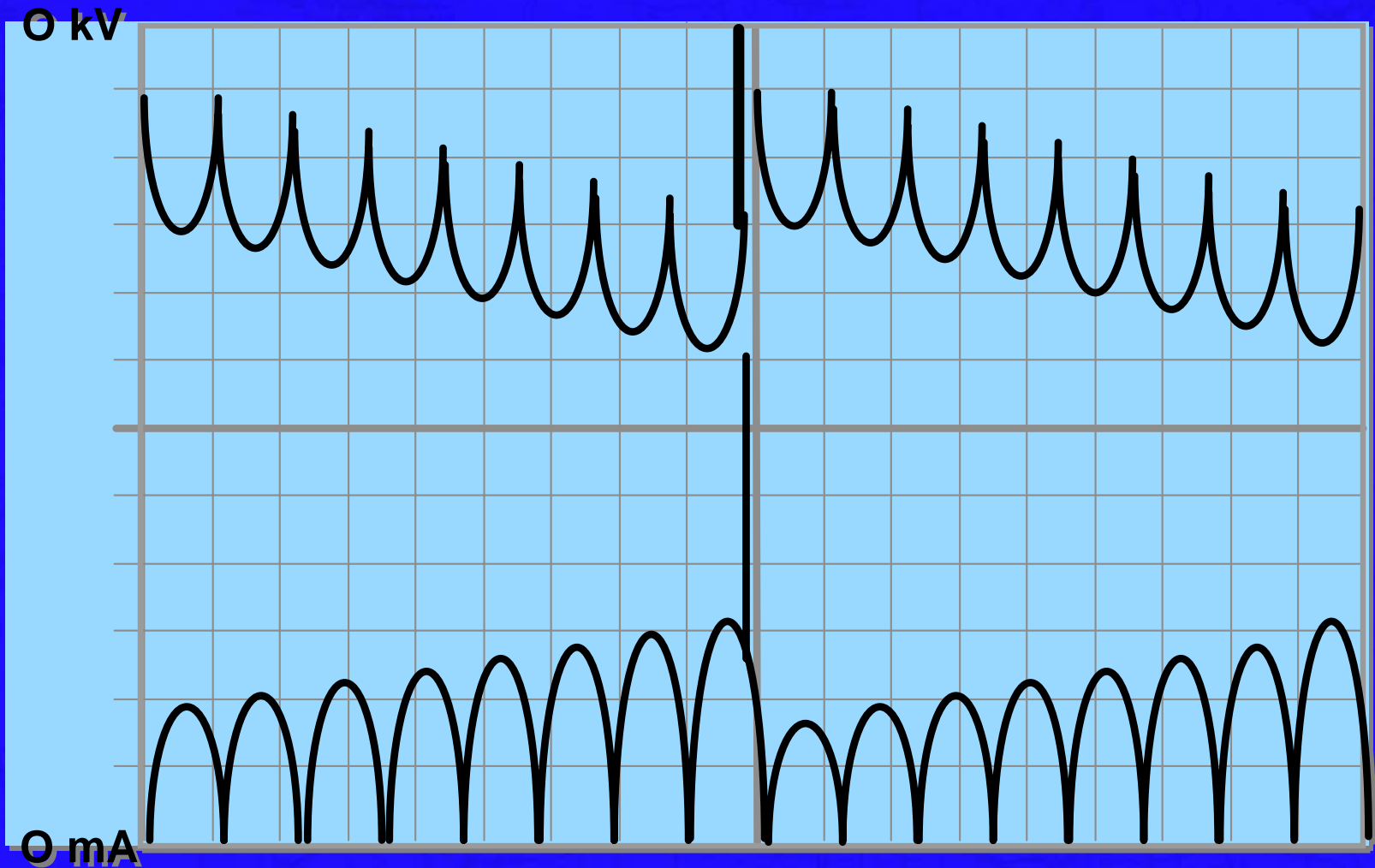

Thank You